



Vertical farming and Plant Factory

垂直農場與植物工廠

方煒

台大生機系教授



Traditional Plant factory

太陽光利用型植物工廠

全環控植物工廠



全環控的植物工廠

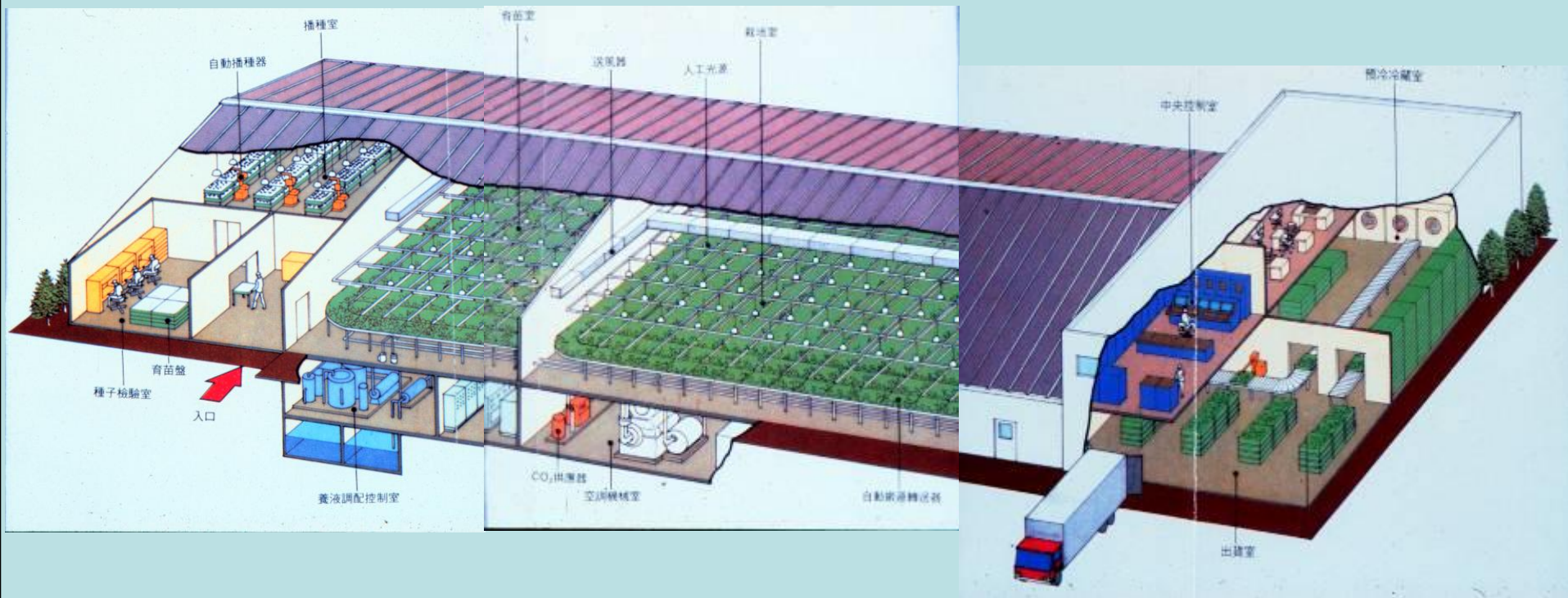

Our Goal

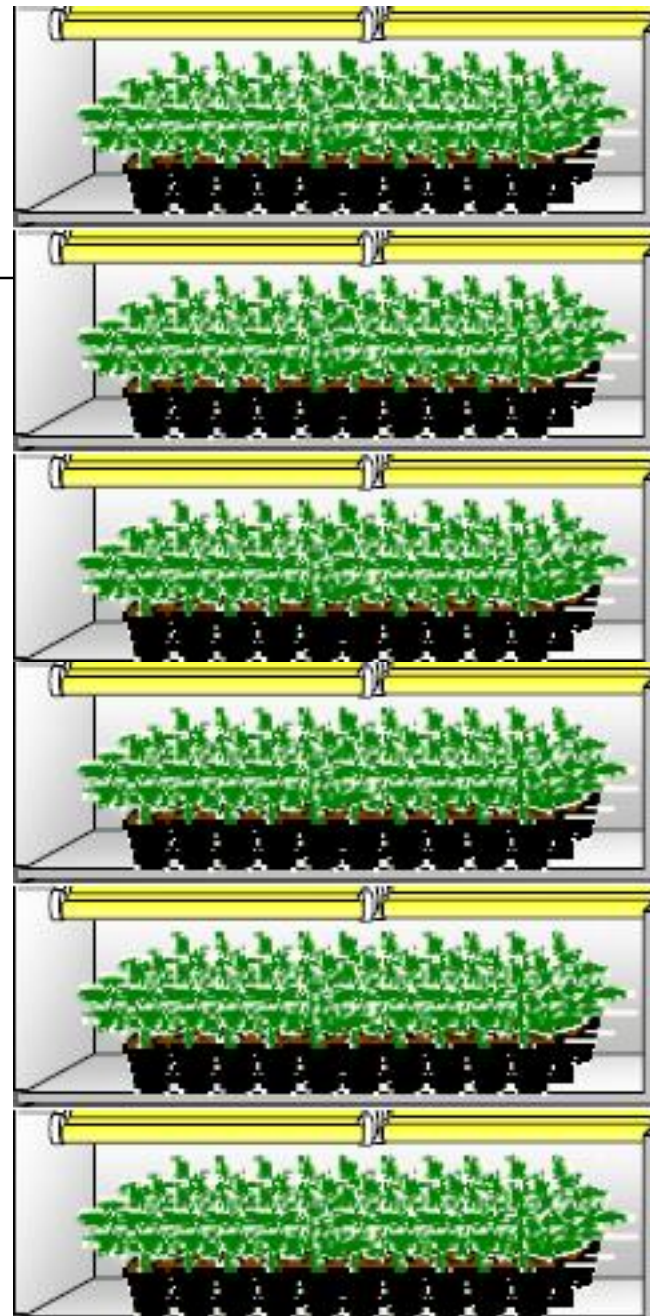

過去的經驗

- 全環控蝴蝶蘭小苗栽培
- 溫度控制
- 濕度控制
- 自走式燈具







過去的經驗

- 全環控組織培養苗栽培
- 溫度控制
- 濕度控制
- 自走式燈具





生菜栽培植物工廠之特點

- 全環控
- 自動化
- 節能
- 高效
- 零病蟲害
- 無農藥
- 低硝酸鹽

日本的Kagome 野菜工廠





日本的生菜LED栽培

Cosmos factory 基礎數據

- 建地 $169 \text{ m}^2 = 13 \text{ m} \times 13 \text{ m}$
- 栽培區 $8 \text{ m} \times 10 \text{ m} \times 10 \text{ 層} = 800 \text{ m}^2$
- 種苗區 + 收穫區 = $169 - 80 = 89 \text{ m}^2$
- 植物栽培用光源為改良型水冷式紅色LED
(660 nm)
- 以薄膜水耕法(NFT)生產生菜、芹菜等葉菜

栽培區



Commercial lettuce production using red LEDs
Cultivation area: 800 m² in 169 m² building (multi-layered system)
Production capacity: 1.5 million lettuce heads per year

栽培區



系統示意圖

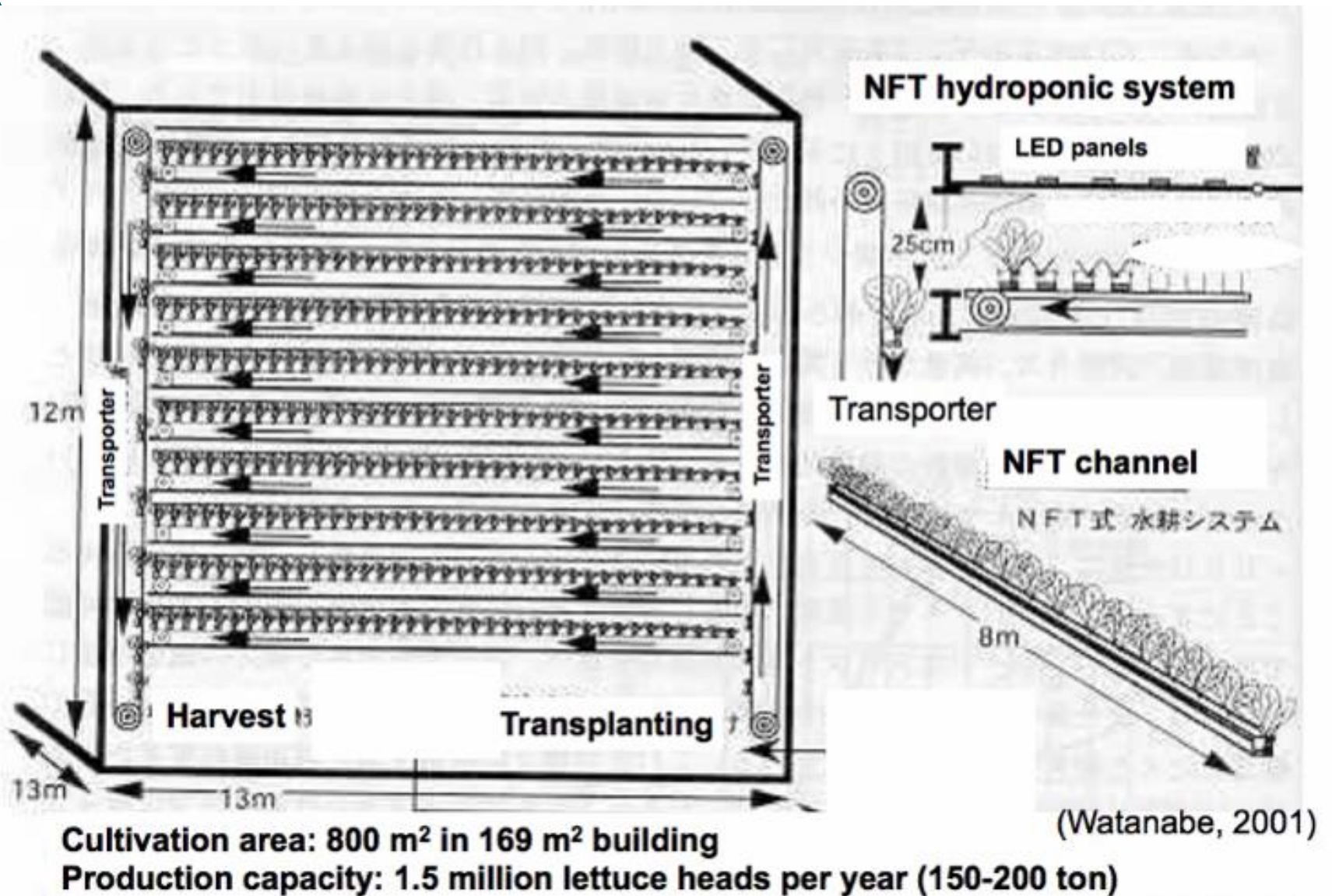

種苗區 → 栽培區



栽培區 → 收穫區



基礎數據

- 150~200 tons/year
 - 187.5~250 kg/m²栽培區地面面積/year
 - 88.7 ~118 kg/m²廠區總面積/year
- 150 萬 heads/year
 - 1875 heads/m²栽培區地面面積/year
 - 887 heads/m²廠區總面積/year
 - 100 ~ 133 g/heads
- 生產能力為5900 株/日
- 254日 x 5900株/日的產能 = 150 萬

- Building 7 sites all over Japan in 2007



紐西蘭生菜LED栽培

基礎數據

- Edible (high quality and tasty) juvenile salad greens
- yield of **3 kg/m²** for an effective **14** days growing time from seed
- at 24°C, **1200ppm CO₂**, 88%RH
- **20-4** hrs light-dark period using a locally built red/blue/green LED array.

基礎數據

- 3 kg/m²/ 14 days
- 這代表 78 kg/m²/yr for 單層 ??

CCD1 2007/03/12 10:04:18





日本千葉大學

無特定病毒種苗栽培

Transplants



Tray





4 shelves x 12 units × 2 rows (384 Trays)
Production Capacity: 270, 000 plants/month
3 million plants/year
Tokushima Seedling Co.



基本單元，地板面積 23 m²



Total Floor Area: 91 m², Contain 488 plug trays or 32,256 Tomato transplants. Annual production capacity of 400, 000 transplants



**Total Floor Area of 476 m² (21 units)
Annual production capacity:
Several million transplants**

中國農業科學 研究院







植物工場是電子技術的板塊。溫度、溼度、CO2濃度、營養素、水質與光的照射量等環境因素，可以經由各種感應器(Sensor)來檢知，所得的環境資訊透過電腦即時處理，控制在所期望的環境條件下。不使用泥土的綠室栽培植物工場，有如半導體工場、液晶工場，不拘泥於既有的食品工場還是流通業者，其他的異種產業諸如擁有電子元件技術或空調技術超強的廠商，也趁勢進攻這個市場。古老有句俗諺「人如其食(You are what you eat)」，旨在說明吃對於人類生體健康的重要性。植物工場走的如此順風，其時空背景與百姓食的安全安心的意識抬頭，有密切的關係。2007~2008這段期間，在日本有大型植物工場陸續在建設中，未來是否會是大型百貨公司或超市的生鮮食料品供應體系，值得去觀察其後勢。

以現階段來講，植物工場的栽培規模與市場都很小，以日本當地來說，生菜(萵苣)的年消費量約是每年50萬噸，而植物工場所栽培的葉蔬菜只不過2500噸，連1%的比例都不到。固然價格較貴，從好的方向來思考，成長空間很大。

在植物工場當中，以完全仰賴人工光的「完全控制型植物工場」最受到矚目。從自然環境的生育環境切離，有計畫性的生產所期望的農作物，系多階段化。通常，植物生產線的配置如同縱方向的書架式構造，每單位面積的生產性比較高。其他還有太陽光利用型的植物工場，使用面積較大。若是藉由IT技術，也可造出小規模工場。

Fairy Angel Inc. 日本

- 第三座植物工廠於 2008 年 8 月 29 日開幕
- 福井縣 美 3 兵 町植物工廠



建設中の福井縣 植物工廠



Fairy Angel

- 京都和千葉有另外兩座
- 完全控制型的植物工廠
- 建築物面積 $3748 \text{ m}^2 = 1135$ 坪
- 建造花費15億日幣
- 每年生產三百萬株植物

頭殼壞掉？

- 假設建築為30年折舊，土地費用不計
- $15\text{億日圓}/30\text{年}=5\text{千萬日圓}=50\text{百萬日圓}$
- $50\text{百萬日圓}/3\text{百萬株}=16.67\text{日圓/株}$
- 假設每年維護費佔建造成本 $1/15$ ，約為 1.11日圓/株
- 合計硬體相關成本攤提為
 - 17.78日圓/株 (30年折舊)
 - 26.12日圓/株 (20年折舊)
 - 51.12日圓/株 (10年折舊)

安全健康蔬菜

400日圓/株

堪稱暴利

Clean room

- 高5.5公尺
- 10層作物
- 清潔品質為一般食品工廠的10倍

- 工人皆穿著防塵衣
- 以立體舉昇機進行收穫









	高壓鈉燈	日光燈	LED
優點長處	<ol style="list-style-type: none"> 1. 每單位輸出的費用較低廉 2. 壽命長 	<ol style="list-style-type: none"> 1. 發熱少，可以近距離照射，可多段化栽培 2. 便宜取得 	<ol style="list-style-type: none"> 1. 可以因應植物最適化的波長 2. 光合成有利的脈衝式照射 3. 小型、輕量化、長壽命、低電壓驅動
缺點短處	<ol style="list-style-type: none"> 1. 植物必要的藍光成分少 2. 發熱量多，不適用於多段栽培 	<ol style="list-style-type: none"> 1. 植物必要的紅光成分少 2. 中央與兩端的光強度不同 	<ol style="list-style-type: none"> 1. 每單位輸出的費用較高 2. 各各的偏移特性大 3. 維護稍難



東京地區

第一個建在商業建築內的植物工廠
技術示範 與 休閒參觀

- 
-
- **In a major business district of Tokyo, a High-Tech Underground Urban Organic Farm provides training to aspiring farmers...**

- 
-
- An underground rice and vegetable field beneath an office building in Tokyo's Otemachi business district.
 - This urban farm - in what used to be the vault of a major bank - is maintained using computer-controlled artificial light and temperature management.
 - It was brought into being by a personnel company as a means of providing agricultural training to young people who are having trouble finding employment and middle-aged people in search of a second career.

-
- The hi-tech vegetable patch, called Pasona O2, is located in the Otemachi Nomura Building in the Tokyo district of Otemachi, where many major corporations have their headquarters.
 - The "field" has an area of about **1,000 square meters**. ***Tomatoes, lettuces, strawberries, and other fruits and vegetables are grown, as well as flowers and herbs (100 different produces)***. There is also a terraced paddy field used to grow rice.
 - In the absence of sunlight, the plants are sustained by artificial light from light-emitting diodes, metal halide lamps, and high-pressure sodium vapor lamps. The temperature of the room is controlled by computer, and the vegetables are grown by a pesticide-free method in which fertilizer and carbon dioxide are delivered by spraying. Hydroponics, in which plants are grown in water and hardly any soil is used, is one of the methods of cultivation used in the facility.

Technical Assistance...

- Prof. Masamoto Takatsuji
School of High Technology for Human Welfare
Dept. of Biological Sci 東海大学開発工学部
Technology
Tokai University
<http://www.ncc.u-tokai.ac.jp/>
- Research field: Agricultural environmental engineering
Plant Factories, Plant culture using LED and LD

Project main sponsor...

- PASONA Group (Human Resources corporation)
<http://www.pasona.co.jp/english/>
http://www.pasona.co.jp/pasona_o2/
- In partnership with Kanto Employment Creation Organization, Inc.
http://www.kantou-kikou.co.jp/company_e.html

GOAL of the project

- Training/Capacity building to create job opportunities in the agricultural sector.
This urban agricultural training facility focus on former "*freeters*" (*Japanese young people who hop between part-time jobs*) with an interest in farming. Through its Agriculture Internship Project in the village of Ogata, Akita Prefecture, Pasona, along with Kanto Employment Organization Inc, offered on-the-job training on a real farm. About 100 aspiring farmers, including young people and middle-aged businessmen, have already taken a course of agricultural training in Ogata. The whole training involves the possibility to receive initiation in farmings skills up to an Agri-MBA within the same the project.
- The facility in Tokyo is open to the public until 6 p.m. to enable businessmen and office workers to drop by and experience hi-tech farming on their way home from work.

NOTES

- The facility in Tokyo is open to the public until 6 p.m. to enable businessmen and office workers to drop by and experience hi-tech farming on their way home from work.
- There are about 15 fully computer-controlled "plant factories" in Japan. Most are located in suburban areas, though, and this is the first such endeavor to make use of a city-center building.



照明機器會產生熱能，需要空調設備來恆溫化。比如說生菜多段化的栽培，需要適切的氣流控制，否則靠近光源的葉先端部會有先枯萎的問題。至於，食用醫療用穀物還是有高度的稻類植物，內部氣流的控制需要更綿密。半導體工場的空調技術就可以派上用場。綠室室內溫度分布的均勻化，對於生產量是有利的。

末了，提供您一個很有趣的訊息。您相信嗎？東京寸土寸金的都心，在大手町地下原本是金庫室的跡地，竟然變成了菜園、花的栽培室。設置了6間房，分別是花園、藥草(香草)園、稻的栽培、果菜類栽培、蔬菜園以及21世紀的植物栽培。

Room 1(花町)主要是以LED照明為中心之花栽培室。屋子中央的花壇搭載了一萬個LED的照明嵌板。為了補足照度，還組合了金屬鹵化物燈(Metal halide lamp)。有各種顏色LED以及半導體鐳射的栽培例。



Location



RECEPTION



CAFETERIA





Map

マウスオーバーで各エリアの説明をご覧になれます。

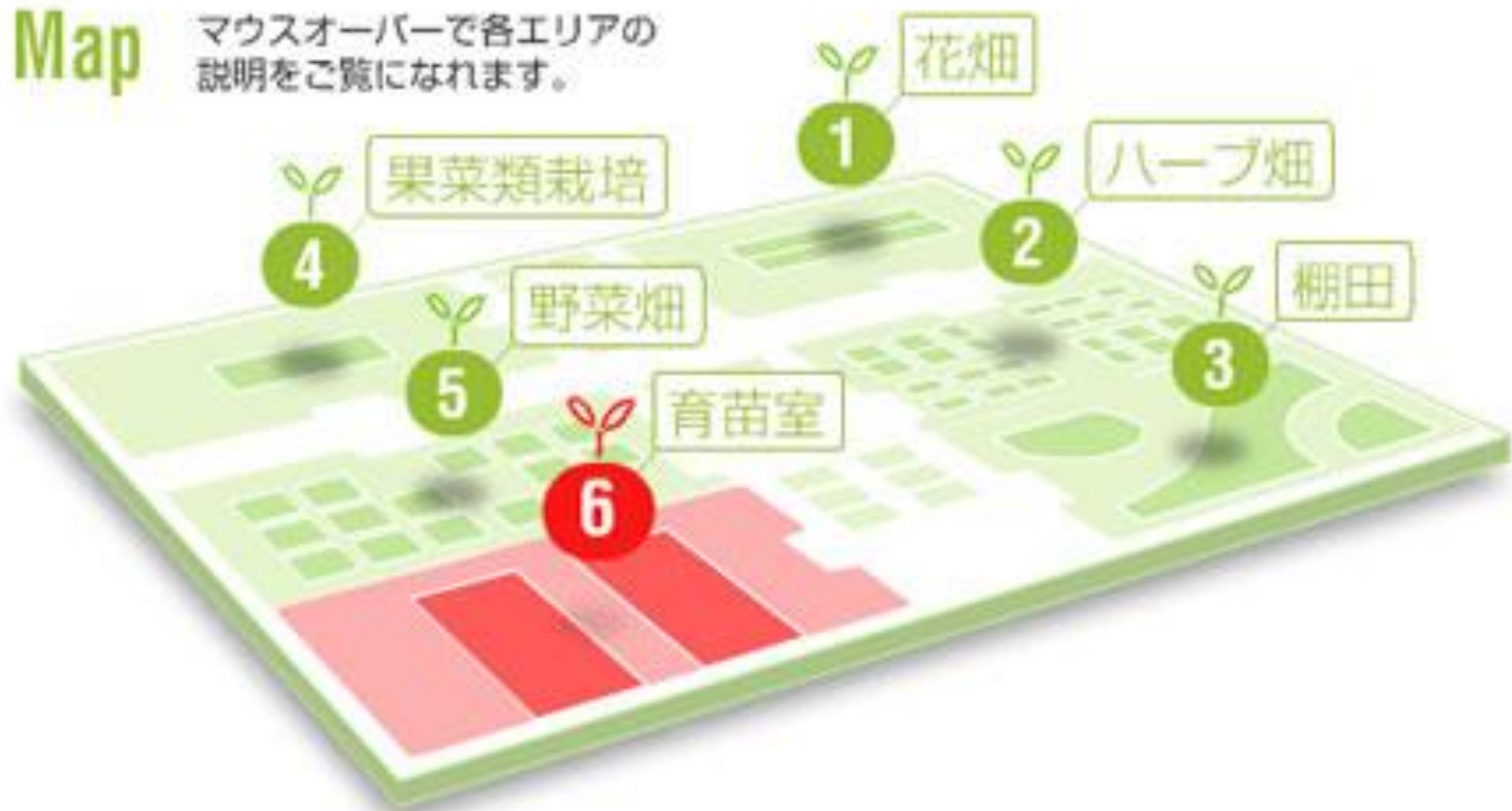

- Room 1** Flower field. White LEDs are used. Plant cultivation by RGB LED.
Metal halids spotlights are used.
- Room 2** Herb field. Metal halids spotlights are used.
- Room 3** Shelf rice field. Metal halids lamps and high-pressure sodium lamps are used.
It explains that it is possible to do by three crops a year.
- Room 4** Fruit/vegetable field. Cultivation of tomato by hydroponics.
3 wavelength, 5000 deg. K, High-frequency fluorescent lamp.
- Room 5** Vegetable field. Metal halids spotlights are used.
- Room 6** Lettuces are being grown with fluorescent lamps.
2xFour steps cultivation bed.

Room

1

花畑

ここでは青色LEDと黄色蛍光材を組み合わせて開発された白色LEDで、花の栽培を行っています。季節ごとに入れ替わる花たちを美しく観賞するためには、演色性(色の鮮やかさ)に優れた白色LEDが適しています。また、植物の育成に必要な波長にあわせ、赤・青・緑のLEDによる植物栽培例を展示しています。



光源 白色/赤色・青色・緑色発光ダイオード(LED)

Flower field. White LEDs are used. Plant cultivation by RGB LED. Metal halids spotlights are used.



Do you [red square]?

PASONA O2

http://www.pasona.co.jp/pasona_o2/

Room 1









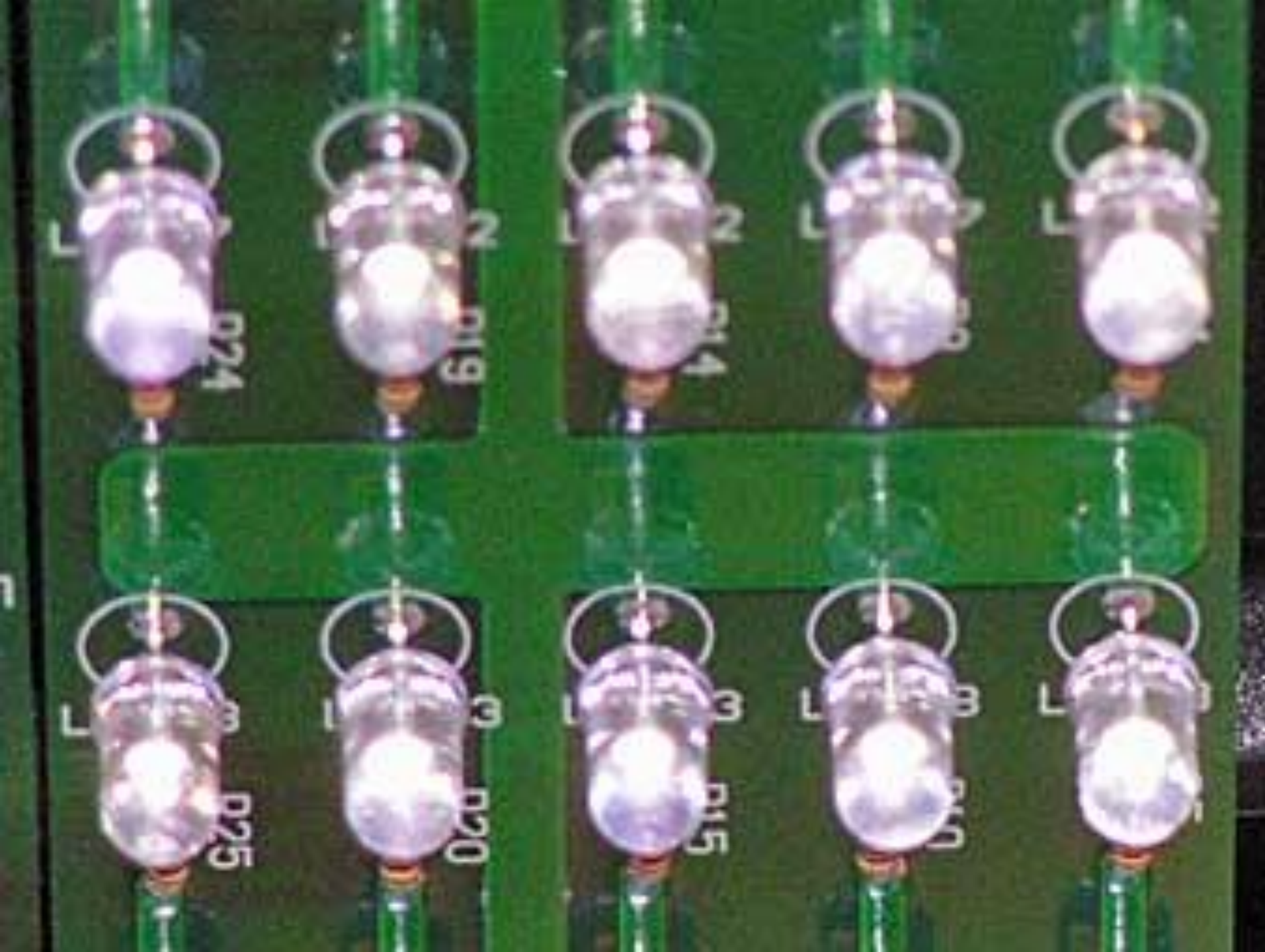

D24

N D19

N D14

B D13

N D12

B D25

B D20

B D15

B D10

B D9













Room

2

バラ・ハーブ畑

ハーブとは種々の香り成分、薬用成分を含んだ植物の総称です。多くのハーブ類は、その生育や有効成分の蓄積に（メタルハライドランプに多く含まれる）青色光を必要とします。また、（高圧ナトリウムランプに多く含まれる）赤色光は開花を促進させる効果があります。ここではこの2種類の光を使って主に香りのよいバラとハーブを栽培しています。それぞれの植物に直接手で触れて、その香りの違いを楽しんでいただきたいと思います。



光源 メタルハライドランプ・高圧ナトリウムランプ

Herb field. Metal halid spotlights are used.

Room 2









Room 2(Herb畑)的照明系組合高壓鈉(Na)燈以及金屬鹵化物燈，維持室內的照度在1萬3000lx。薔薇在室內栽培室困難。以人工環境來栽培薔薇開花的早。2007年3月定殖苗，一個月後開始開花。



Room

3

稲の栽培

人工光(太陽光に近い色であるメタルハライドランプと寿命が長く効率が良い高圧ナトリウムランプ)によって、稲を栽培し、棚田の景観を再現しています。栽培方法は、栄養分を溶かし込んだ水を流して育てる養液栽培です。温度・日長・養液濃度などを生育段階に合わせて調整し、生育をコントロールしています。ここでは理論的に年3回の作付けが可能です。



光源 メタルハライドランプ・高圧ナトリウムランプ

結合高壓鈉燈與金屬鹵素燈，允許一年三期稻作





Room 3









Room

4

果菜類栽培

植物栽培に自然の土壌を用いず、生育に必要な栄養分を溶かした養液を用いて栽培する方法を水耕栽培もしくは養液栽培といいます。植物の栄養条件を常に最適に保つことにより、植物を自然の状態よりも早く、大きく、効率的に栽培することが可能です。通常は背丈ほどの大きさのトマトですが、ここでは葡萄棚の様に多くの実を見て頂ける方法で栽培しています。



光源 蛍光灯

**Fruit/vegetable field. Cultivation of tomato by hydroponics.
3 wavelength, 5000 deg. K, High-frequency fluorescent lamp.**

Room 4











Room 4(果菜類栽培)，利用日光燈的番茄栽培室。利用水耕的方式，將必要的肥料成分與空氣中的氧氣溶入水中。日光燈的周圍配置了反射板，提高照度1.5倍。





Room

5

野菜畑

近年ハウス栽培が普及し、野菜の端境期がなくなりました。現在では主要野菜の半分近くがハウス栽培されています。この延長上に野菜を人工的に栽培する野菜工場があります。ここでは光源としてメタルハライドランプと高圧ナトリウムランプを使用し、様々な種類の野菜を実験的に栽培しています。



光源 メタルハライドランプ・高圧ナトリウムランプ

Vegetable field. Metal halids spotlights are used.

Room 5



Room 5蔬菜園組合高壓鈉(Na)燈以及金屬鹵化物燈，室內的照度在1萬5000lx。可同時培育夏季蔬菜與冬季蔬菜。



Room

6

21世紀型の植物栽培

光や温度などの環境条件を人工的にコントロールすることによって、天候や場所に左右されずに、植物を連続的に生産することができます。収穫までの時期も短縮でき、露地栽培のものと変わらない栄養豊富な野菜が収穫できます。ここでは蛍光灯を利用した4段式栽培施設2台によって、無農薬・新鮮・清潔なサラダ菜を主に栽培しています。



光源 蛍光灯

**Lettuces are being grown with fluorescent lamps.
2xFour steps cultivation bed.**

Room 6



















Do you 農?

PASONA  O2

http://www.pasona.co.jp/pasona_o2/

http://www.pasona.co.jp/pasona_o2/

日本 京都 結合餐廳與室內栽培



可預見的未來問題

- 目前世界人口約60億
- 目前適合栽種作物的土地已經使用了80 %

- 2050年世界人口將增加30億
- 需要的栽種面積為120 % ?

- 世界各地食物價格不斷上漲
- 海平面上升，可耕地減少
- 環境（空氣、土壤、水）污染問題嚴重



Vertical Farm Skyscraper

立體栽培的農場大廈

can be one of the solutions

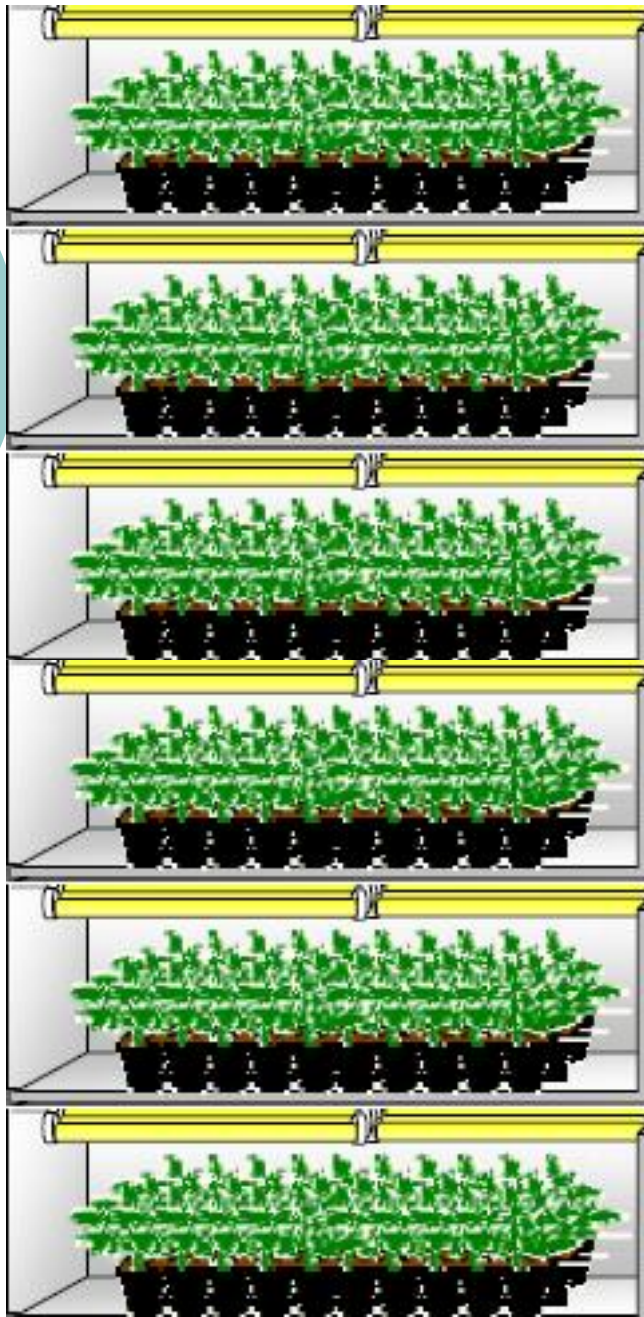

頂樓搭配太陽能或風能發電的設備示意圖





Agricultural skyscrapers ——未來農業發展構想



Vertical Farm Skyscraper

- 1999年 美國哥倫比亞大學 Dickson Despommier教授提出構想
 - 在市中心建立一座每年生產1200萬株萵苣的建築，21層高，占地588英畝
- 建造費用4500萬歐元(約22.5億台幣)
- 每年維護費270萬歐元(約1.3億台幣)

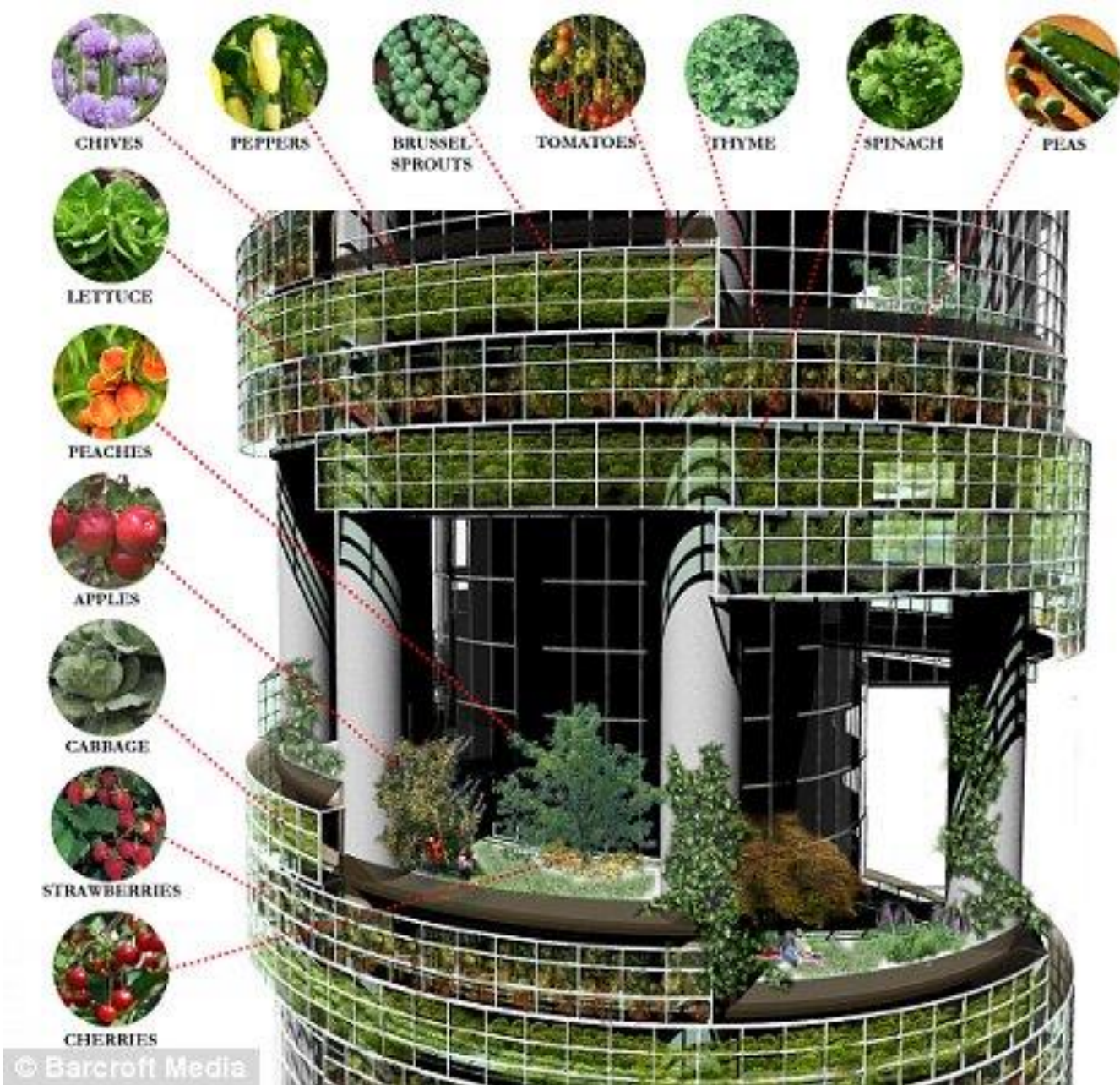

The skyscraper concept is gaining more attention as world food prices soar. The designer claims one farm could produce 12 million lettuces a year



<http://www.dailymail.co.uk/sciencetech/article-1061036/Blue-sky-thinking-The-skyscraper-farms-feeding-millions-2050.html>

頭殼壞掉？

- 假設建築為30年折舊，土地費用不計
- $22.5\text{億}/30\text{年}=7.5\text{千萬}$
- $7.5\text{千萬}/1.2\text{千萬株}=6.25\text{元/株}$
- $1.3\text{億}/1.2\text{千萬株}=13/1.2=10.83\text{元/株}$
- 合計硬體相關成本攤提為
 - 17.08元/株 (30年折舊)

安全健康蔬菜

100元/株

尚稱合理

New Vertical Farm Design

Designs by Chris Jacobs of www.unitedfuture.com
Modeling and Rendering by Dean Fowler.

Note: These are pre-visualization renders...and do not show color, trees, "green," hydroponic plants, etc. This is an early pre-visualization.

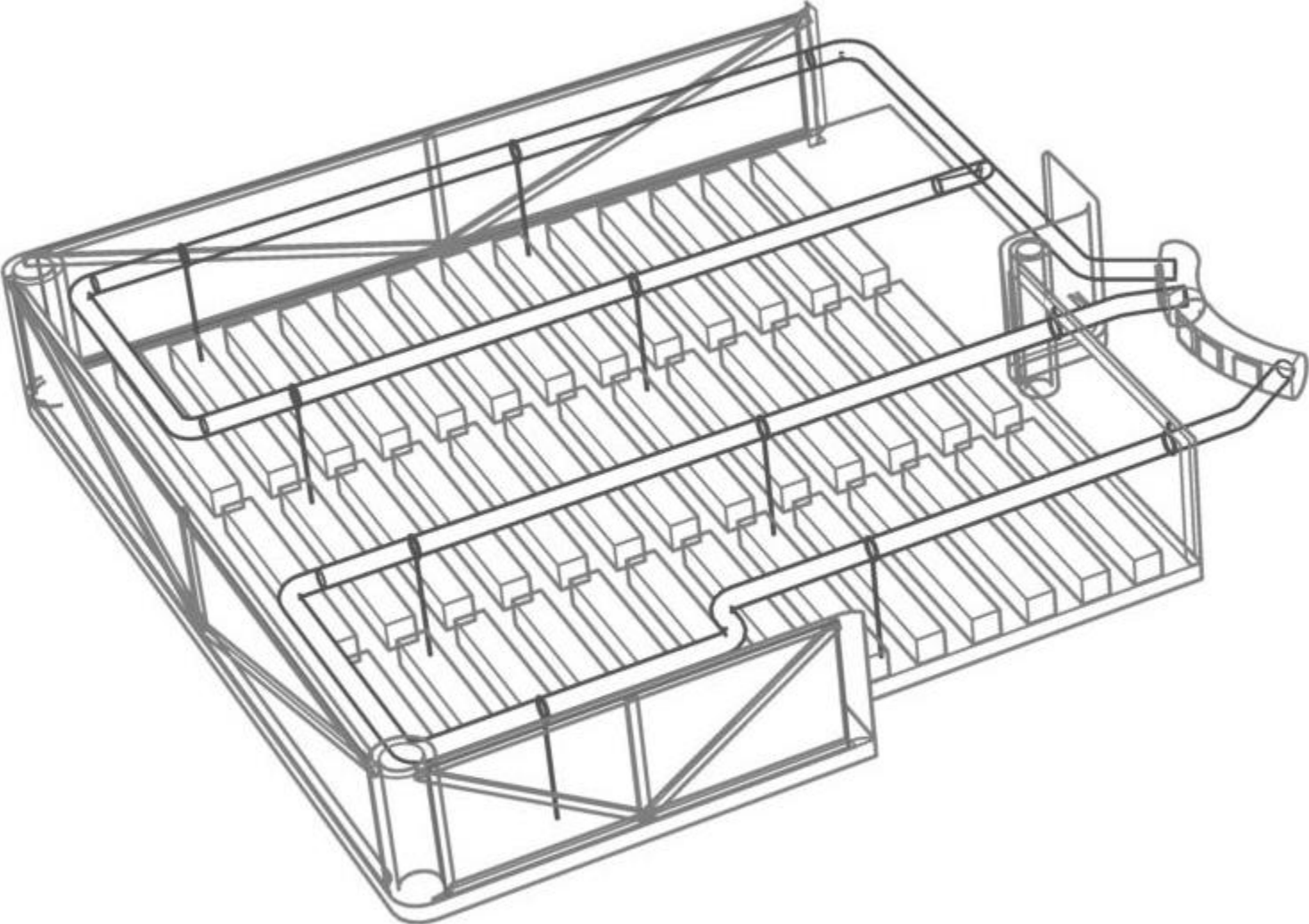

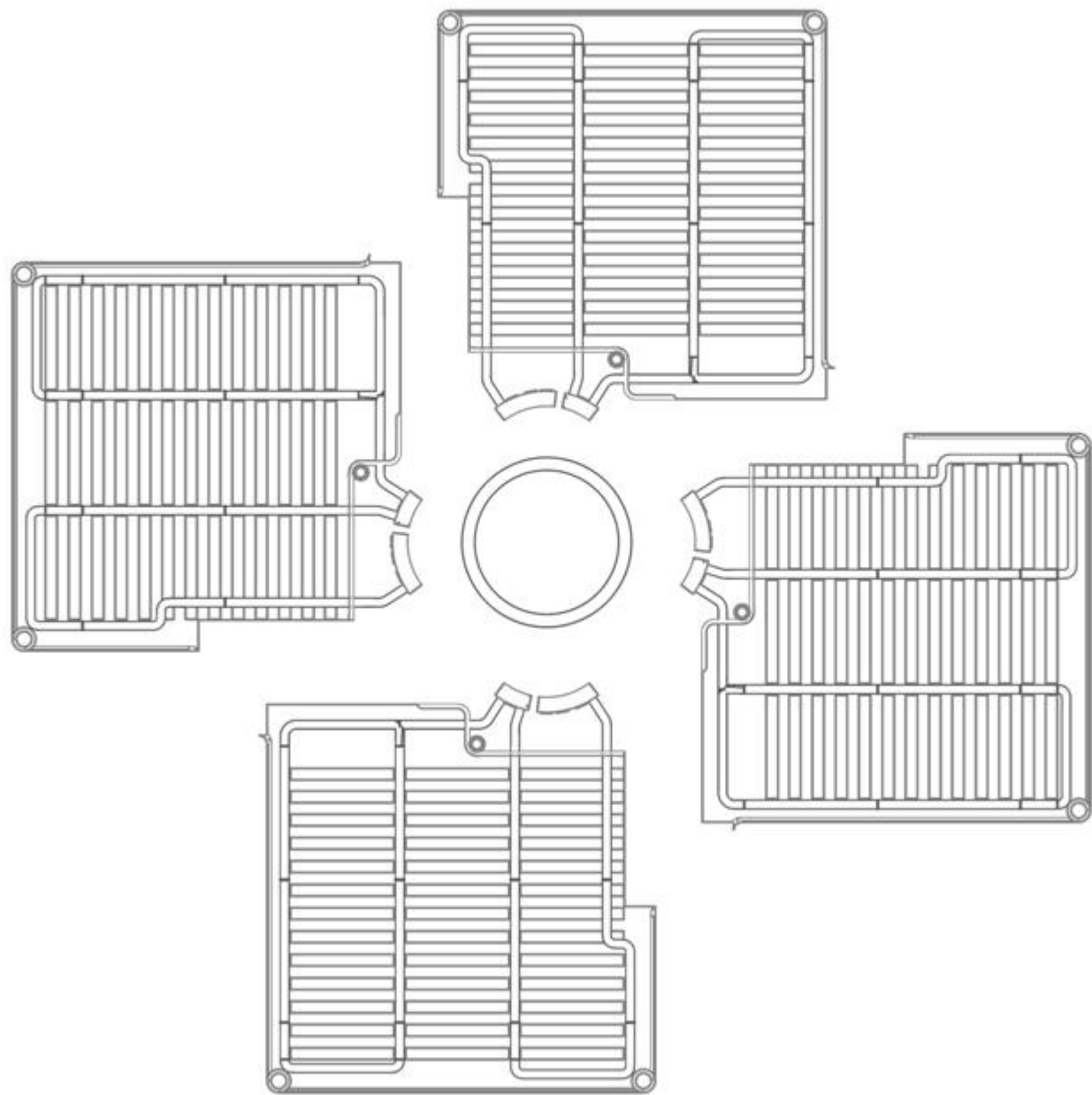

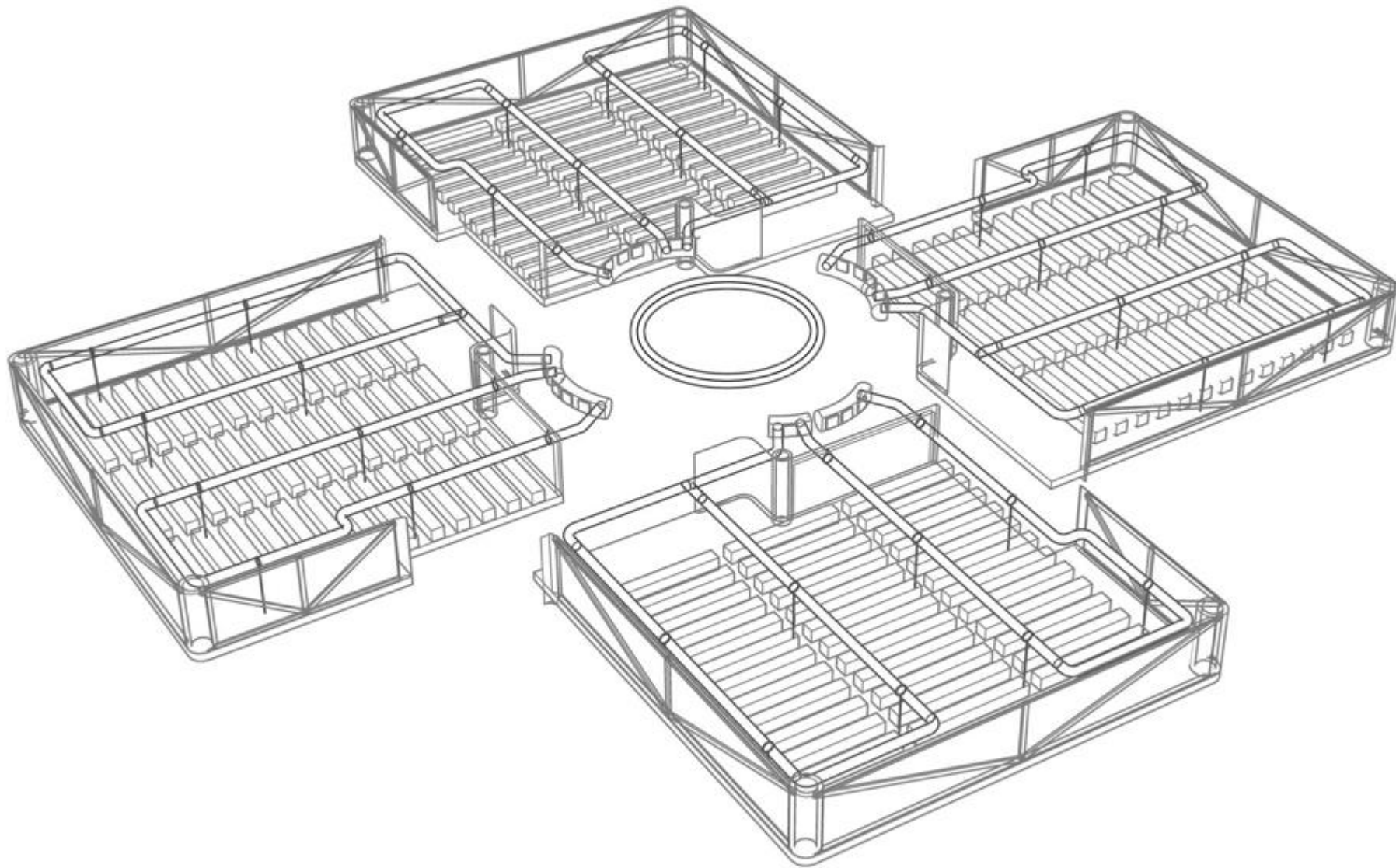

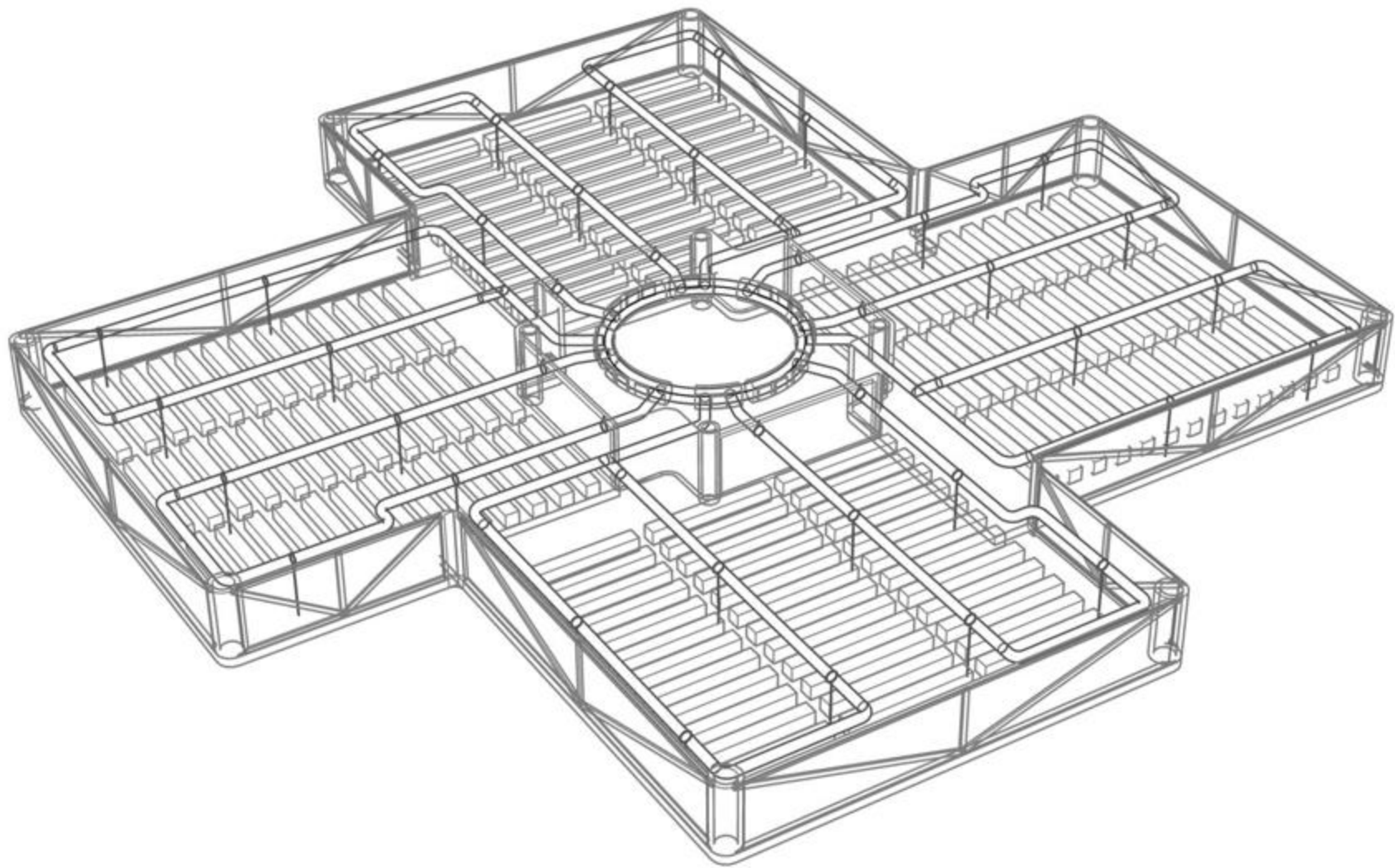

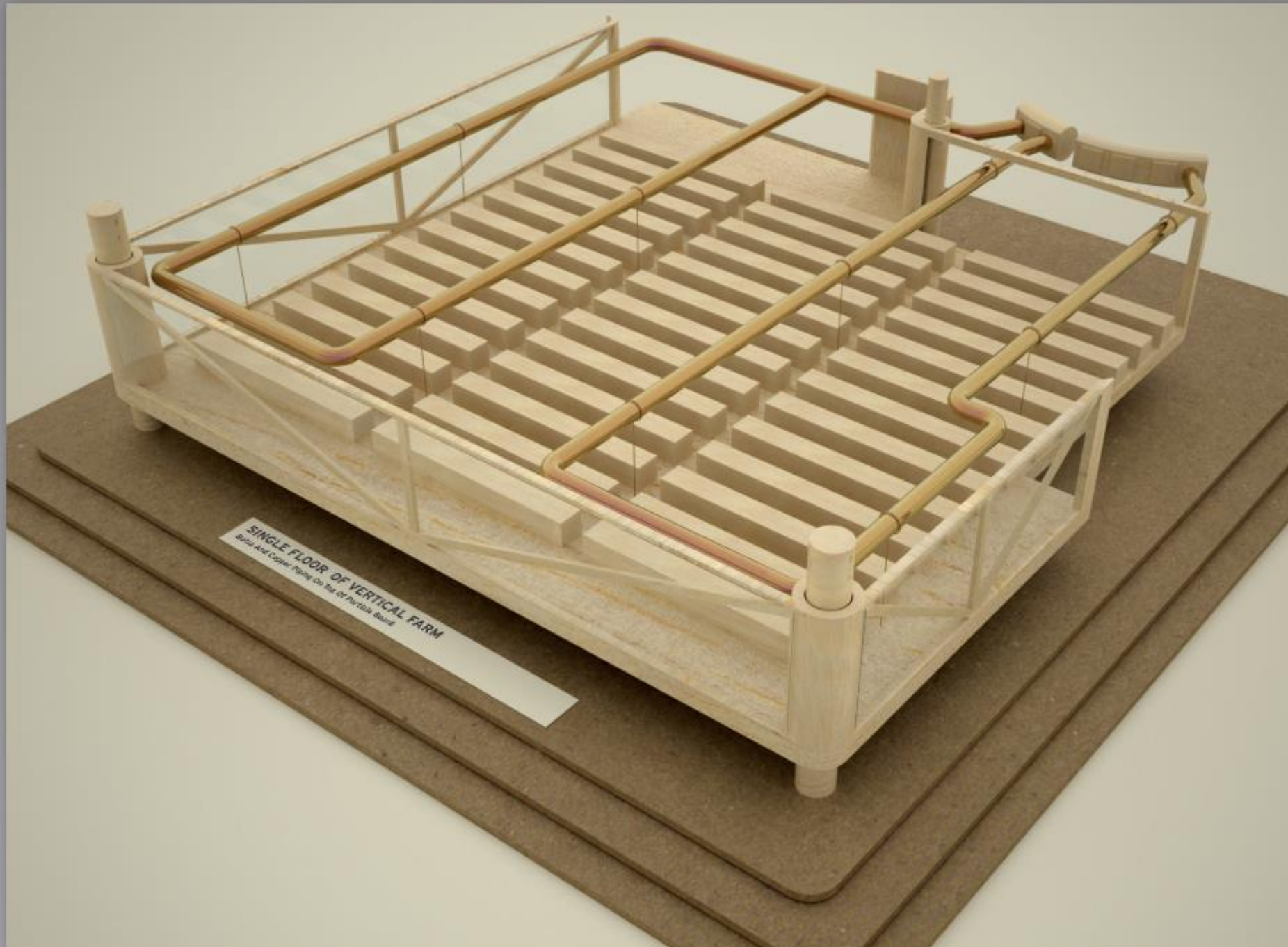

SINGLE FLOOR OF VERTICAL FARM
Beds And Copper Pipes On Top of Particle Board

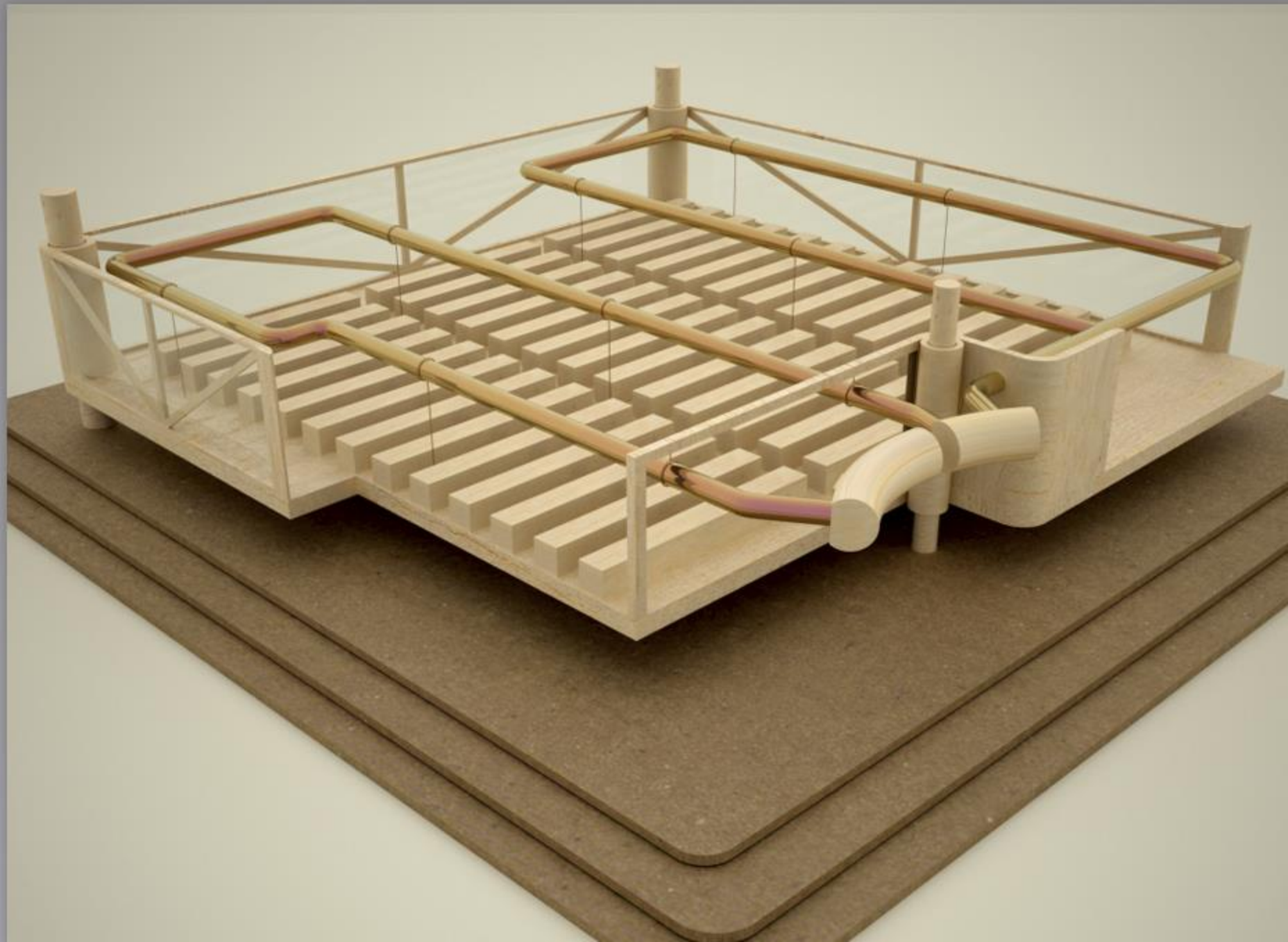

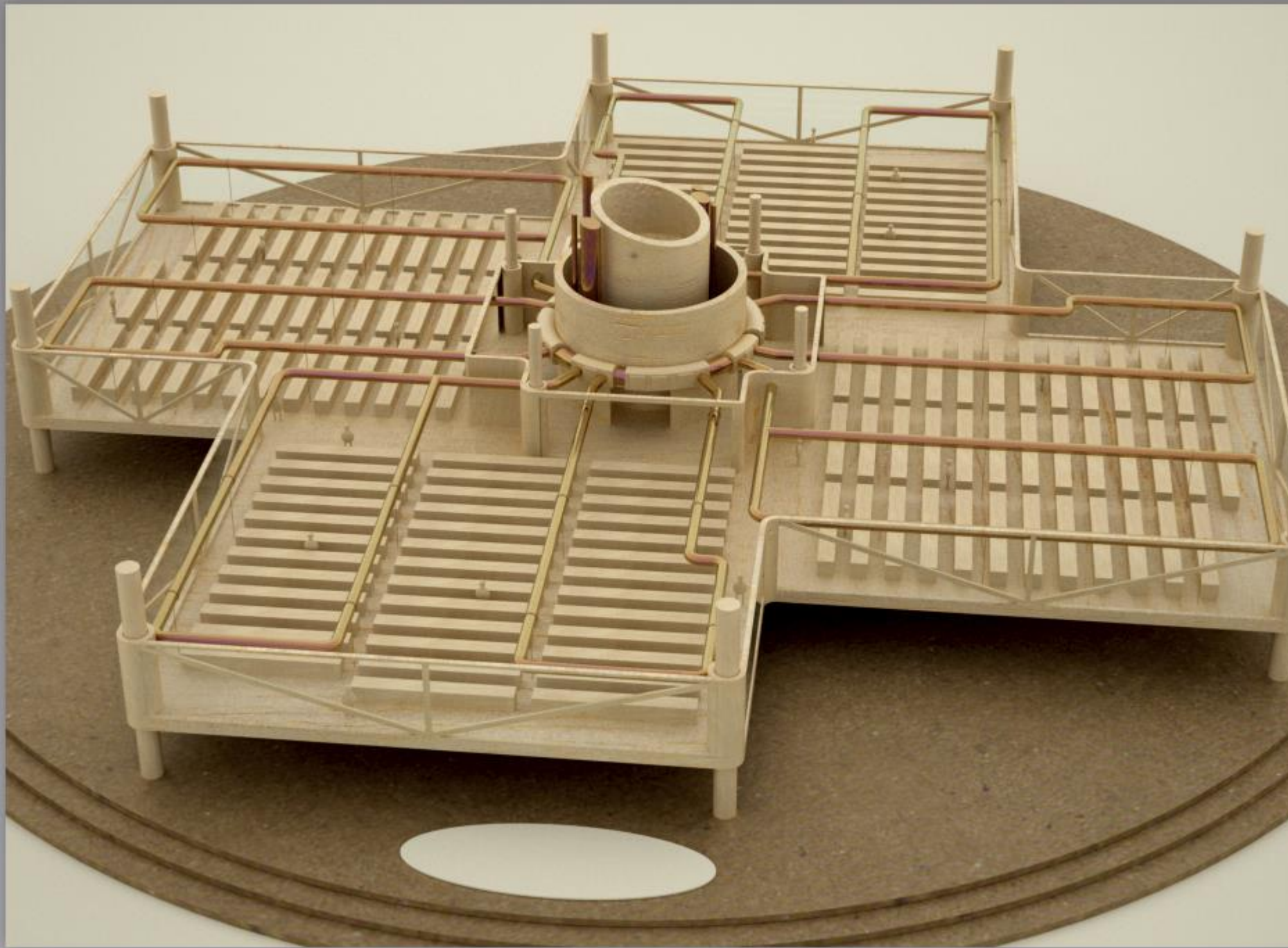

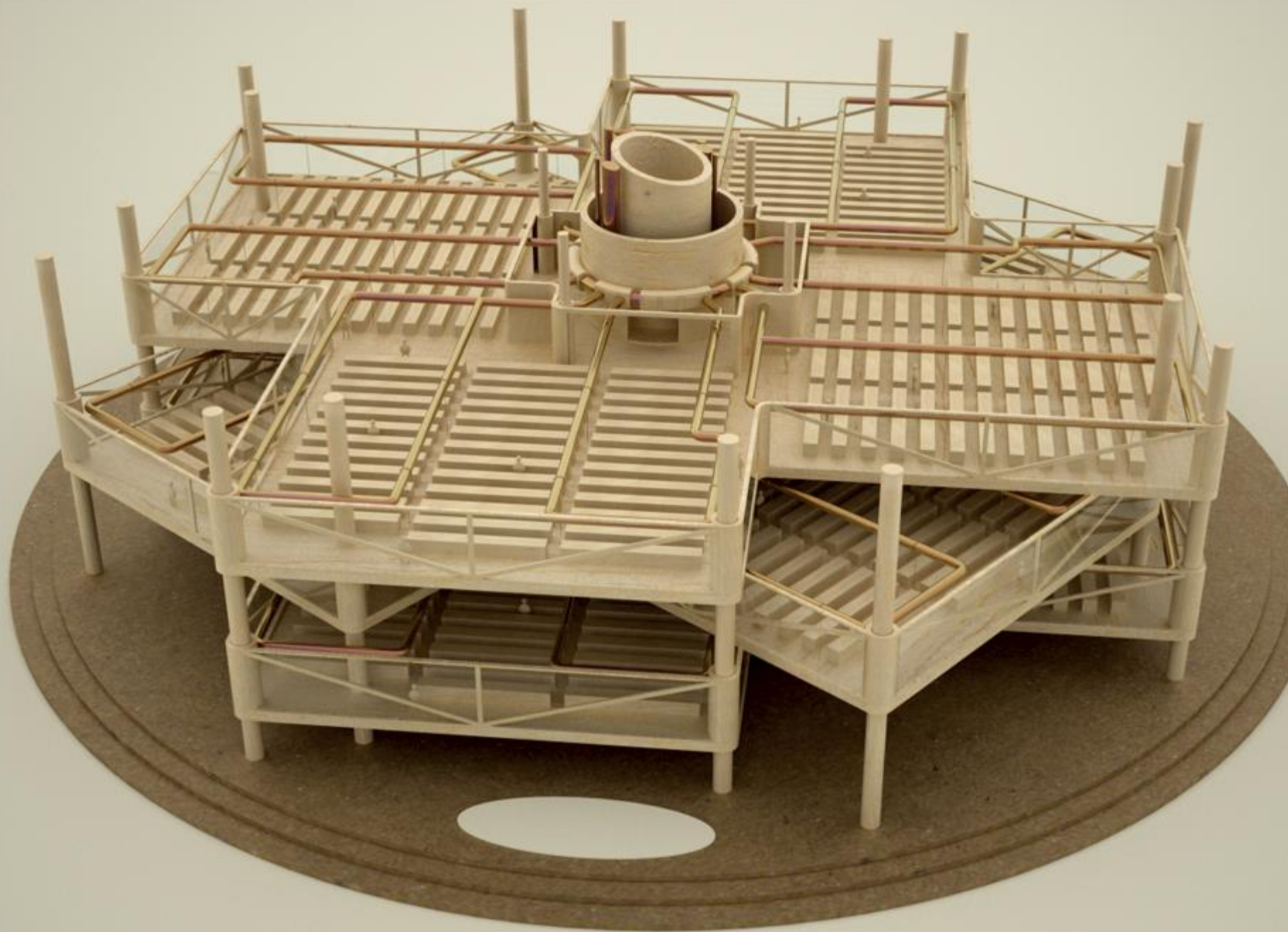

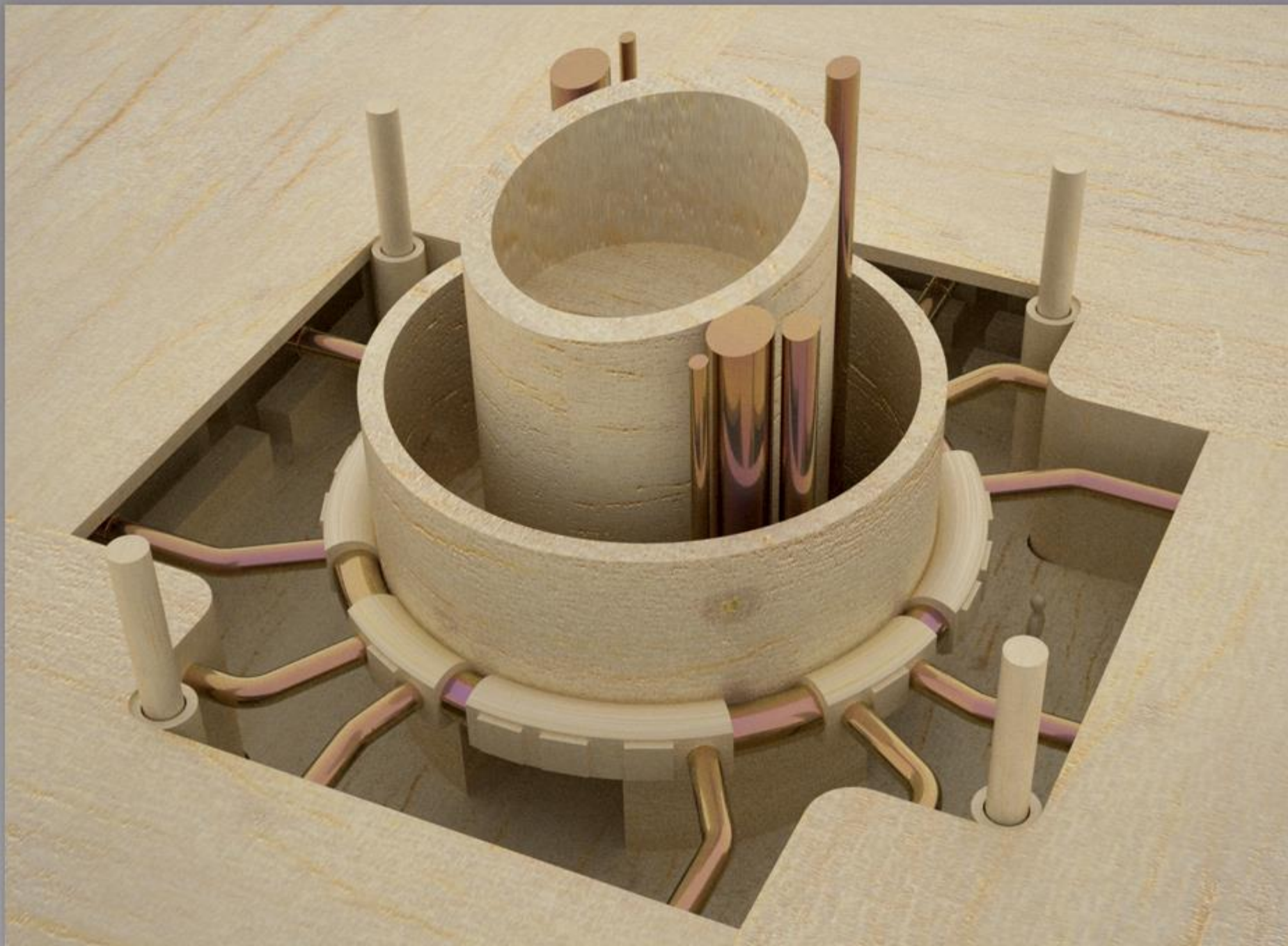

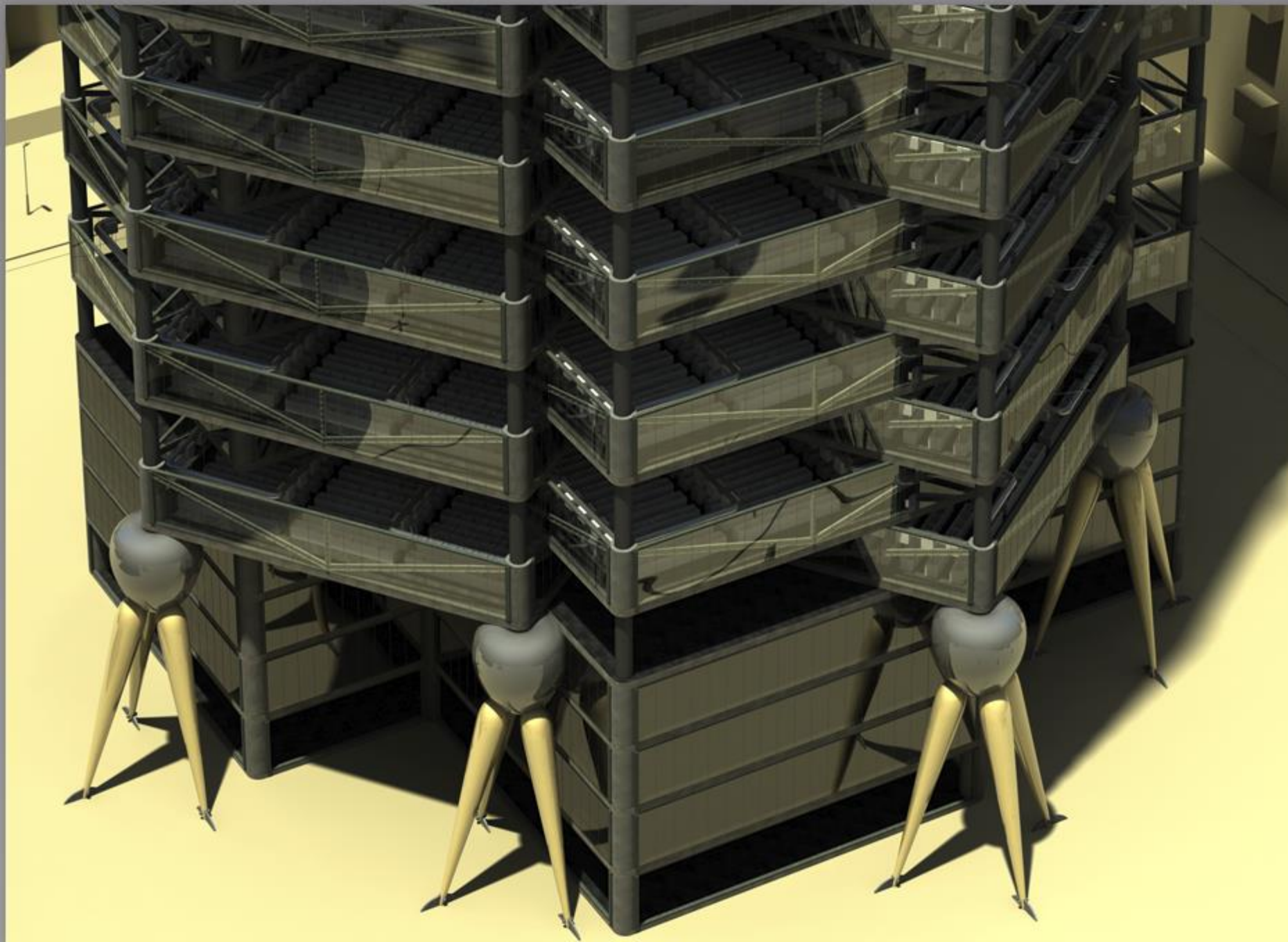







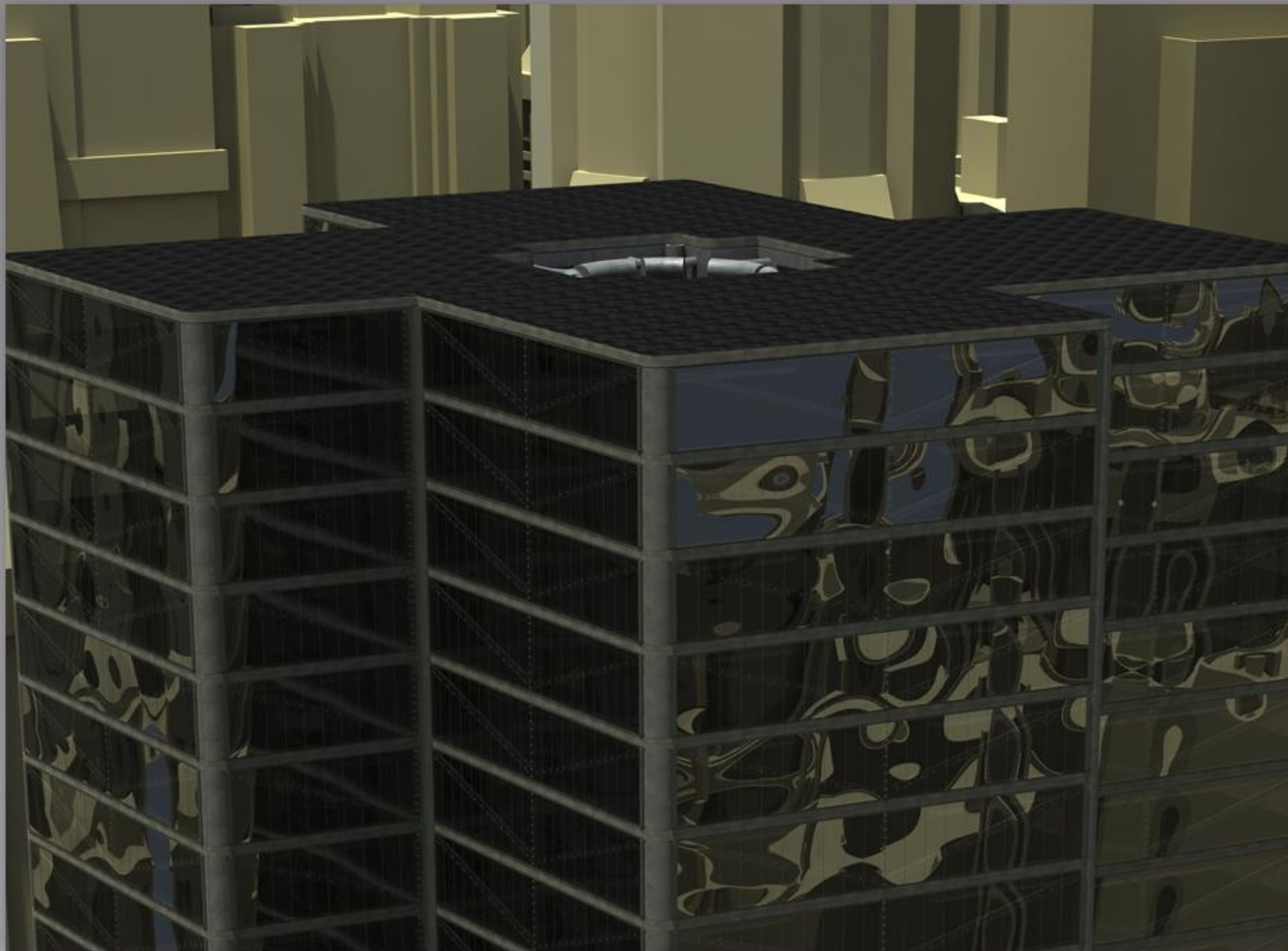

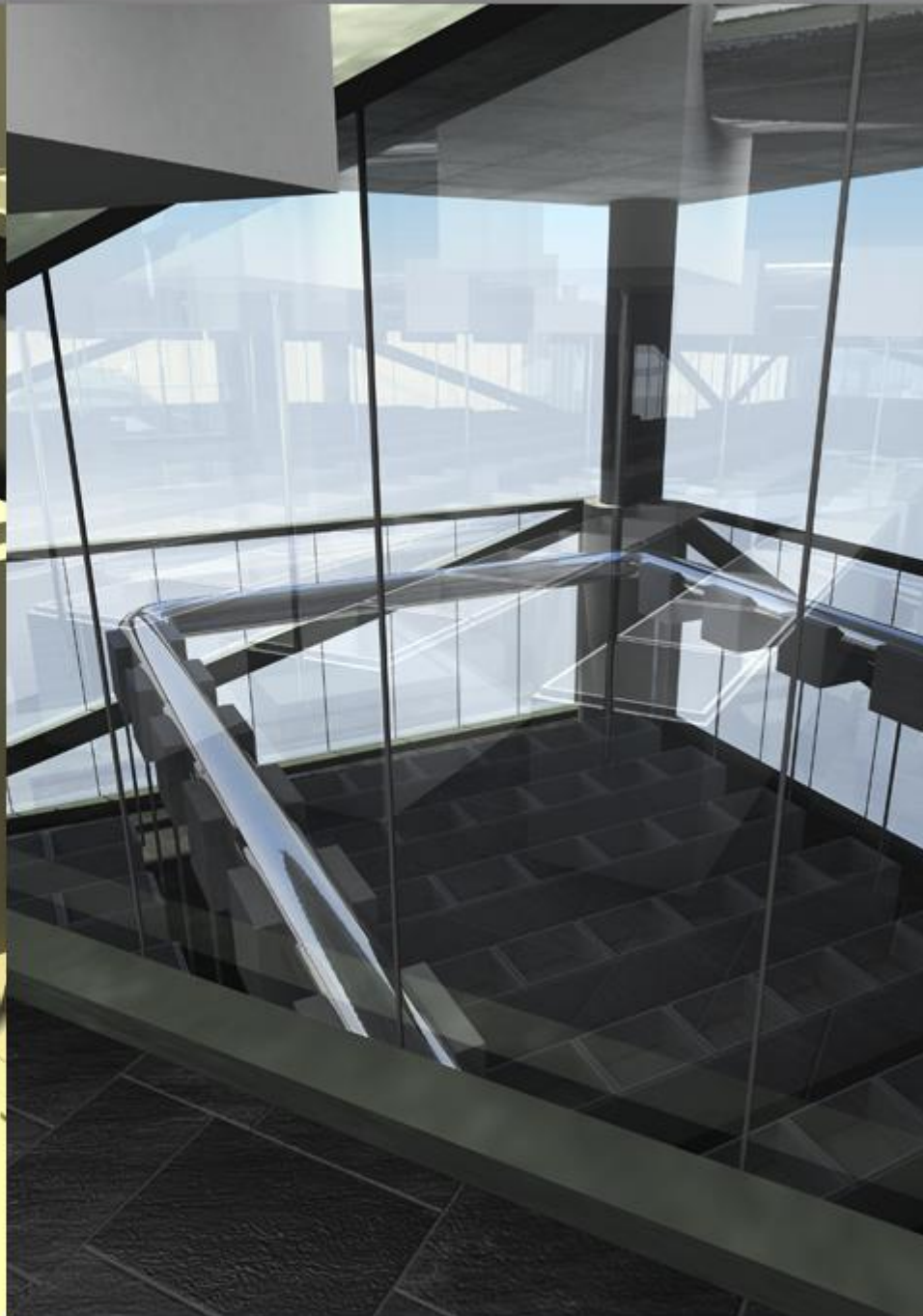
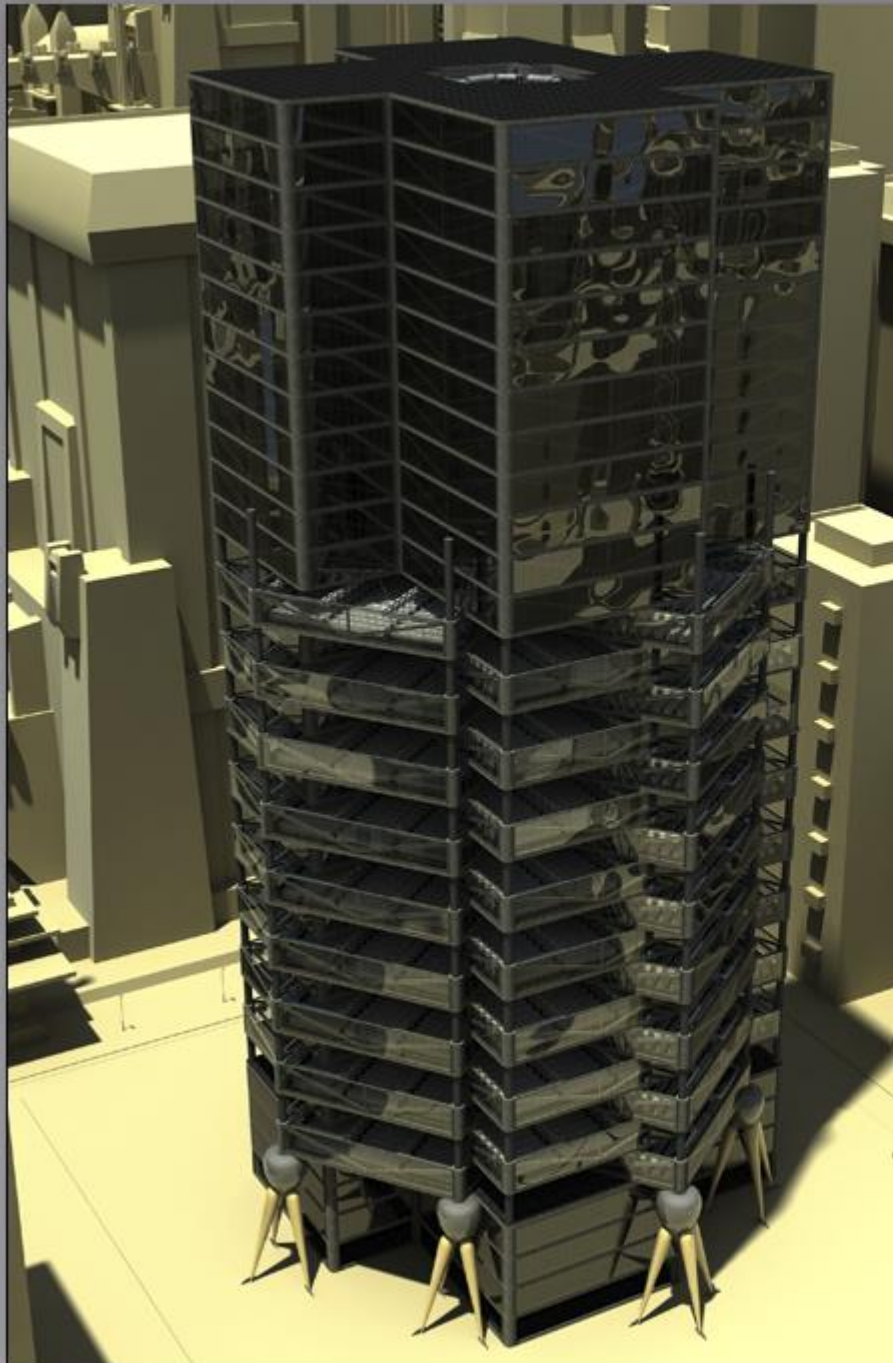



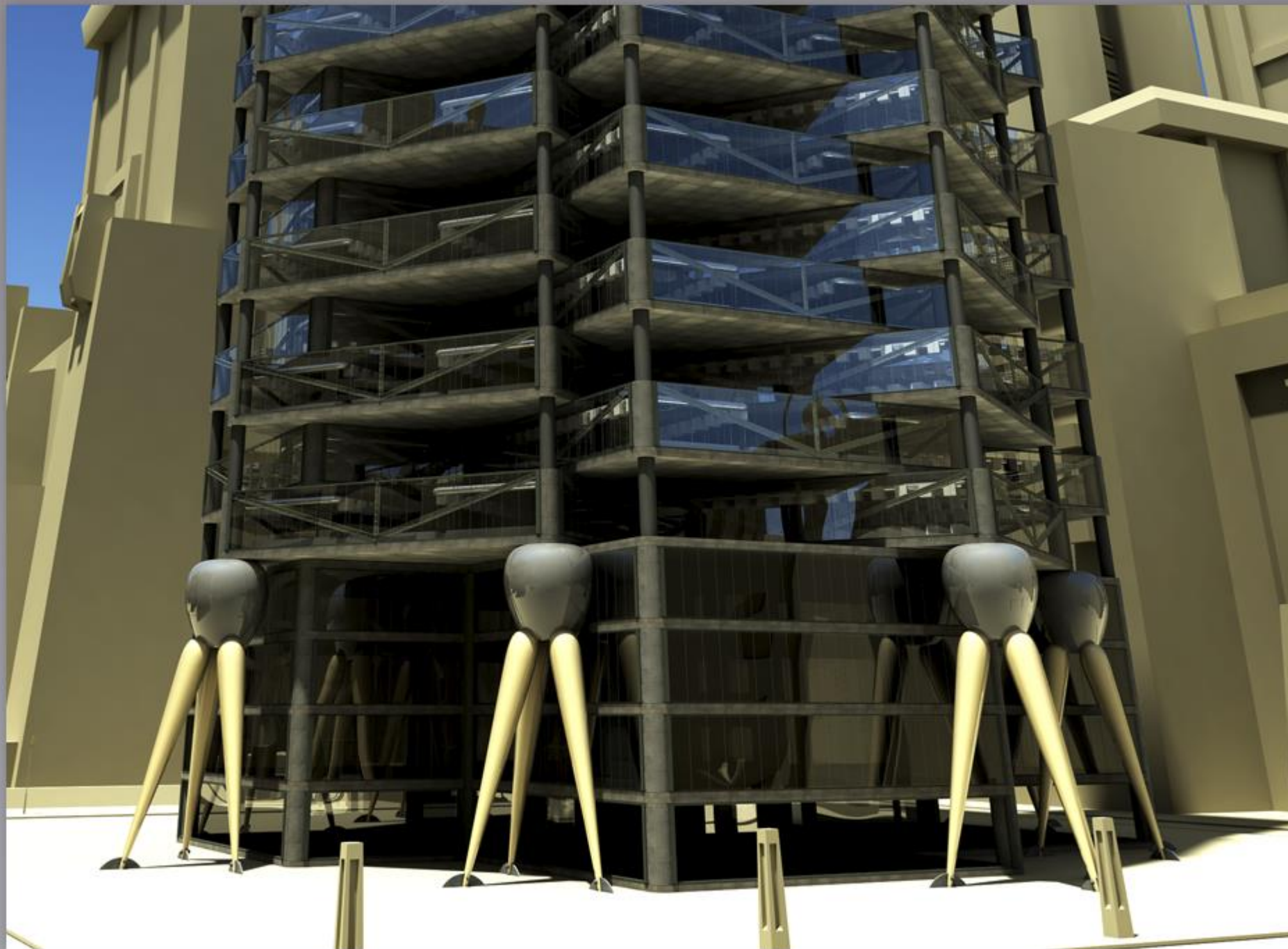

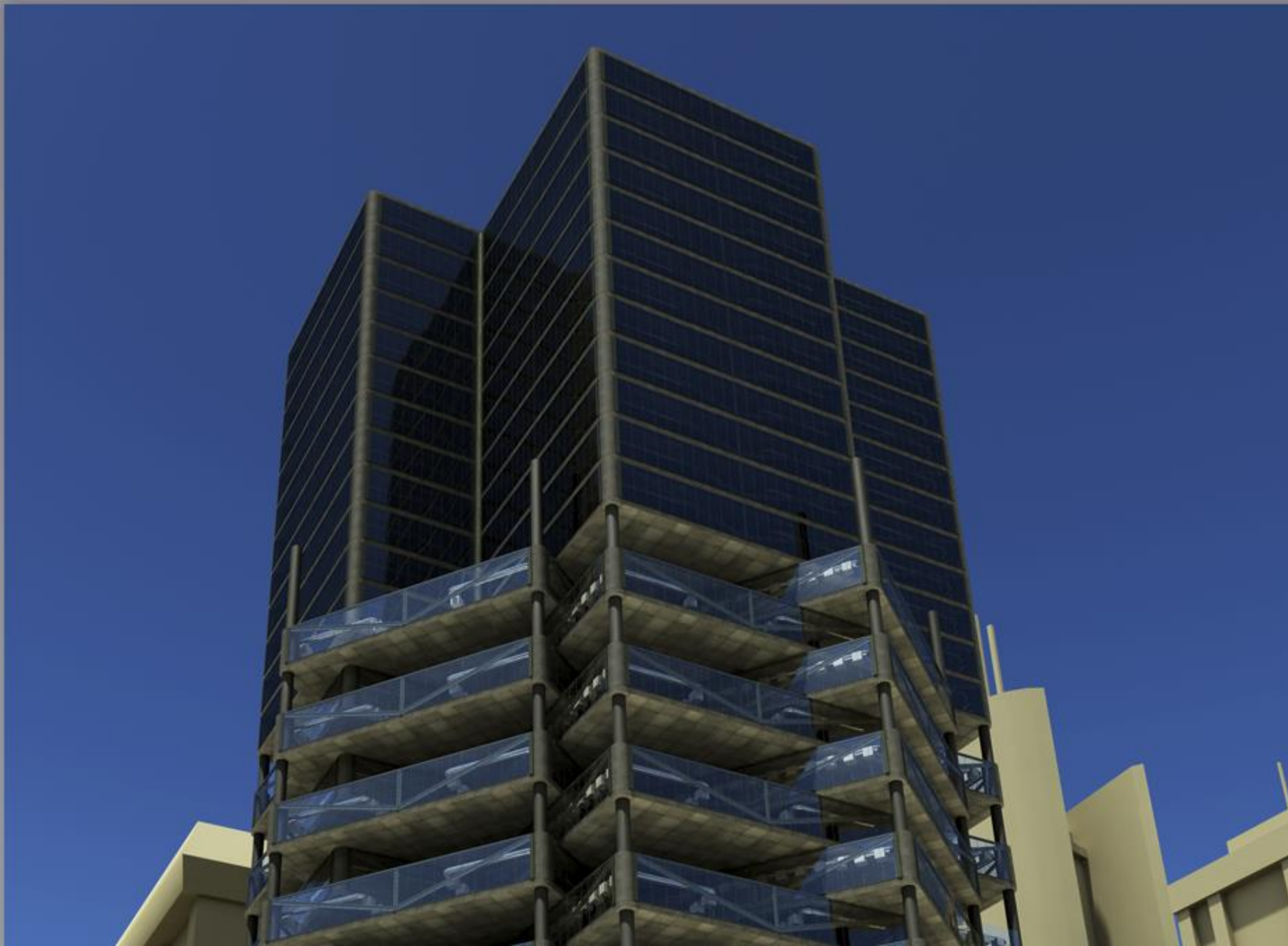



Vertical farms could also work in **pyramid** form





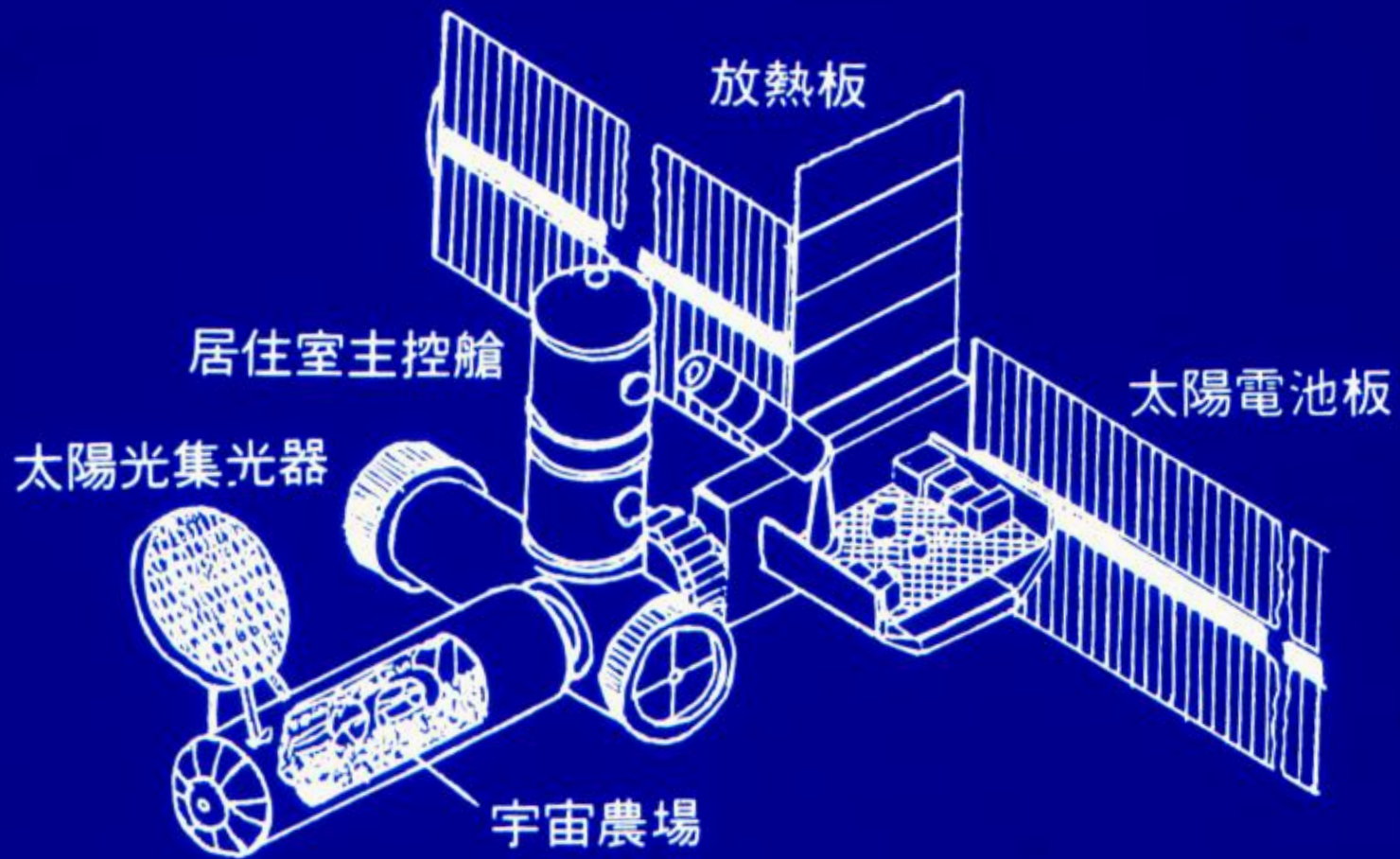

宇宙基地植物工場的概念圖

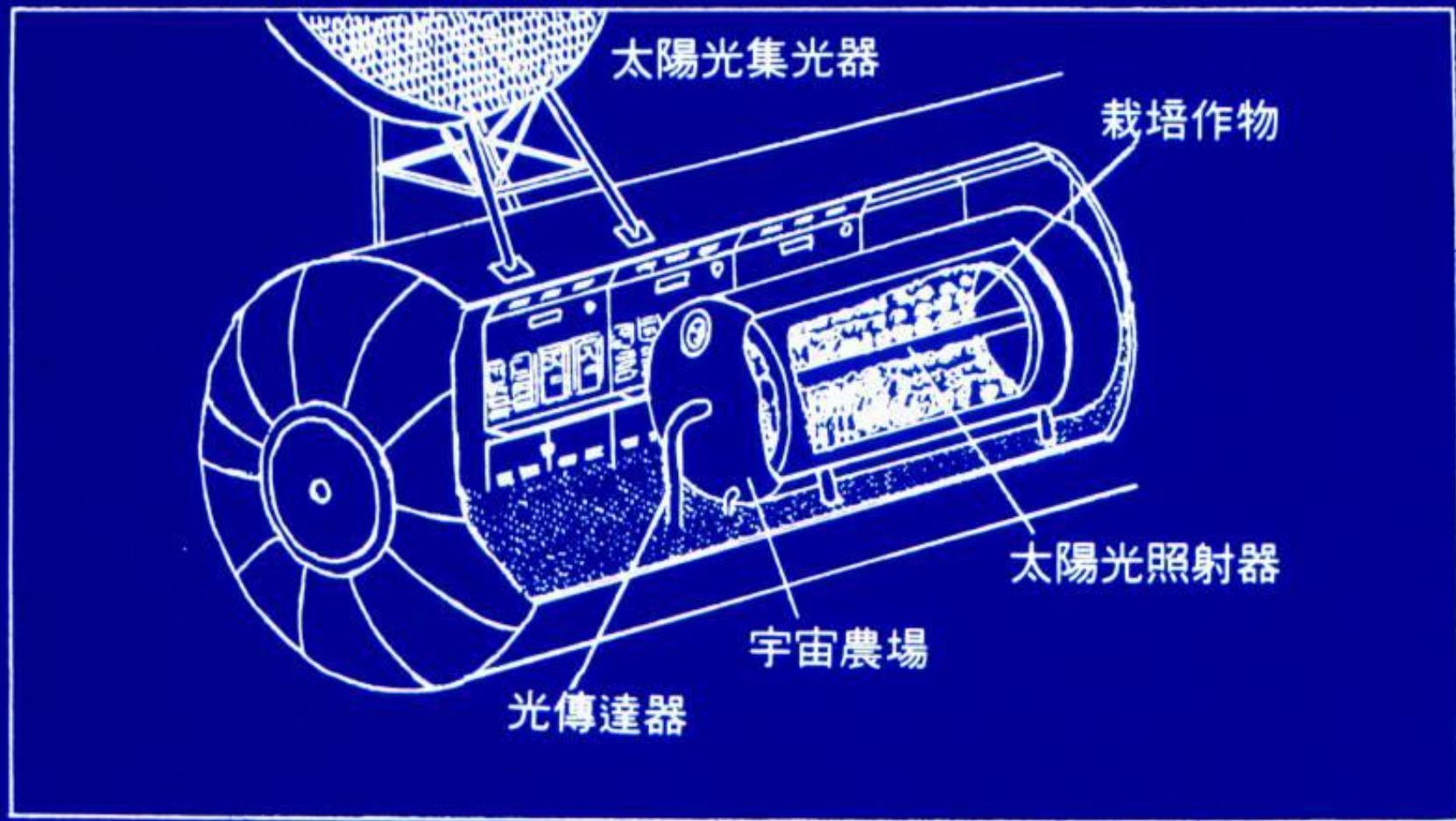

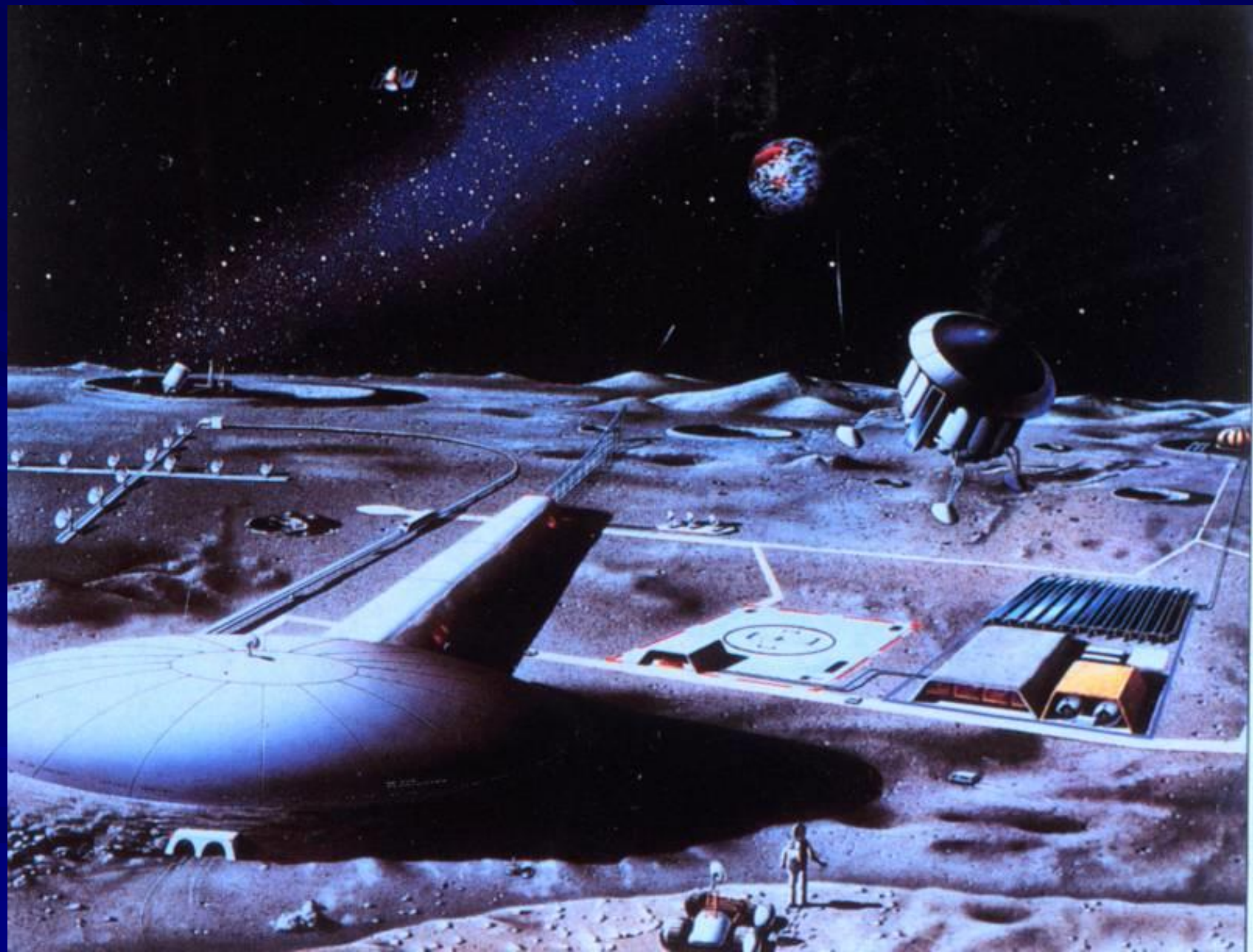

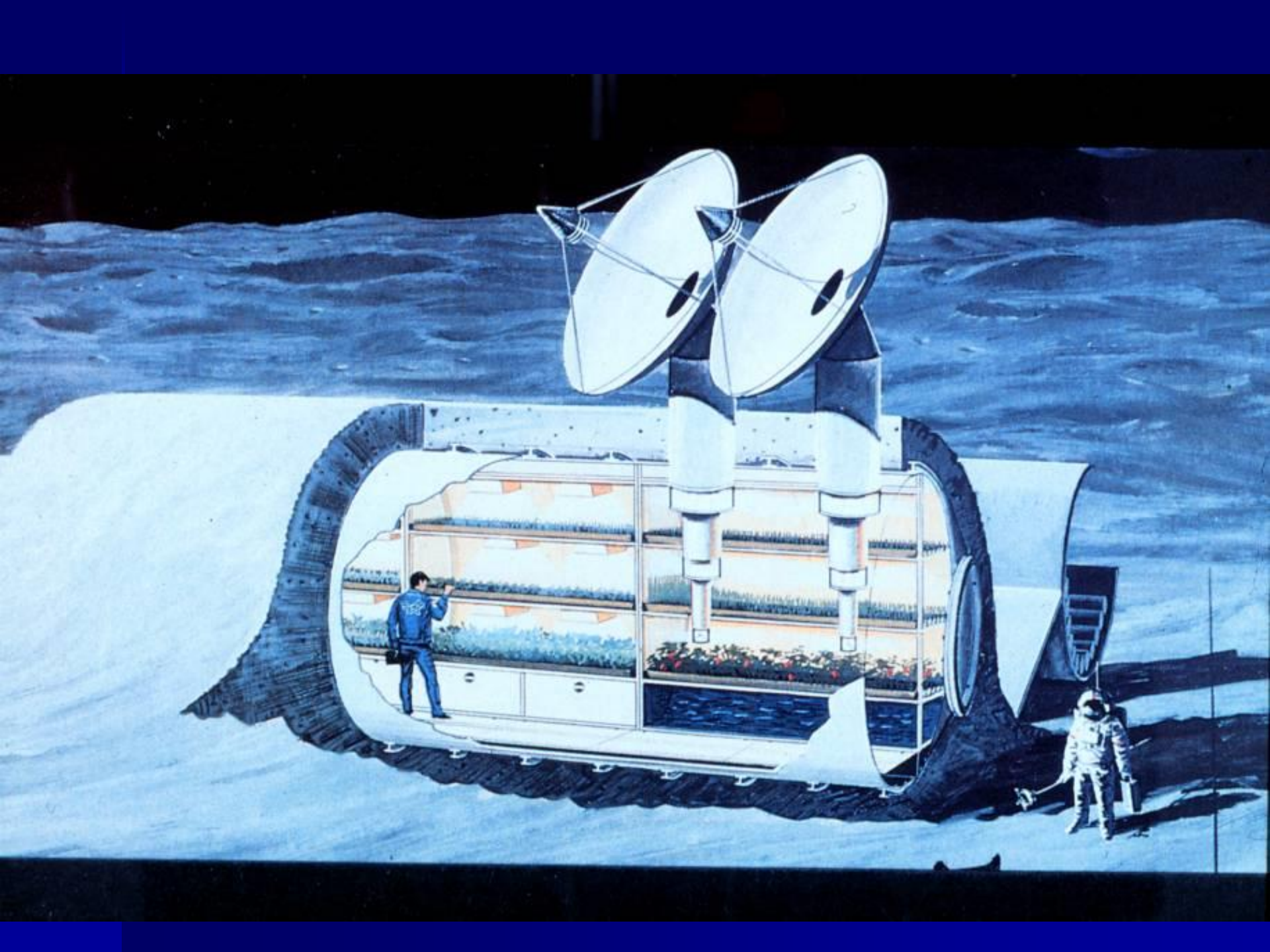

謝謝聆聽

